

Low Profile Air Gripper  
**Series MHF2**



Low profile air gripper with space-saving design is newly released.

# Low Profile Air Gripper

# Series *MHF2*

Height is approximately 1/3 the size of an equivalent Series MHZ2.

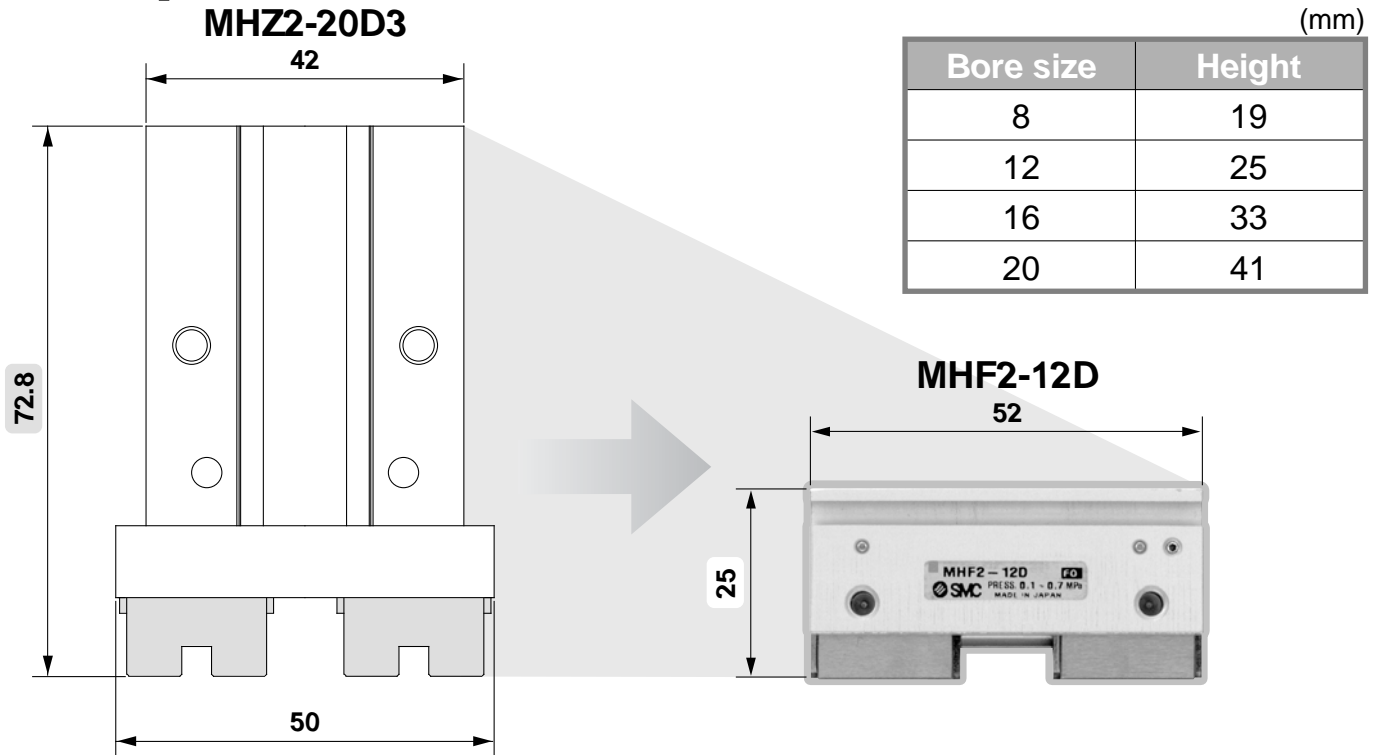

- The low profile design saves space and reduces bending moments.
- Improved accuracy with smooth operation

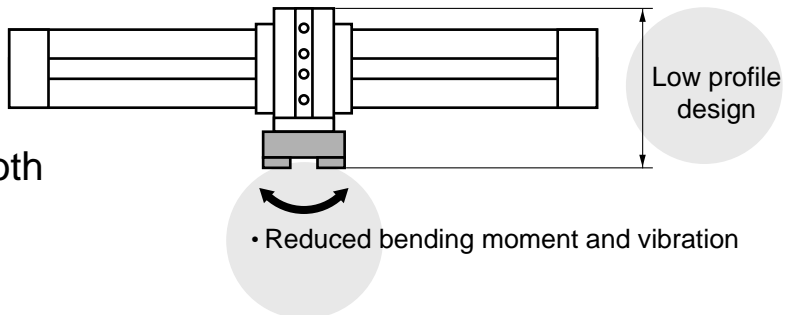

## Stroke selection is available.

3 standard stroke lengths are available for each bore size. Stroke can be selected to suit the work piece.

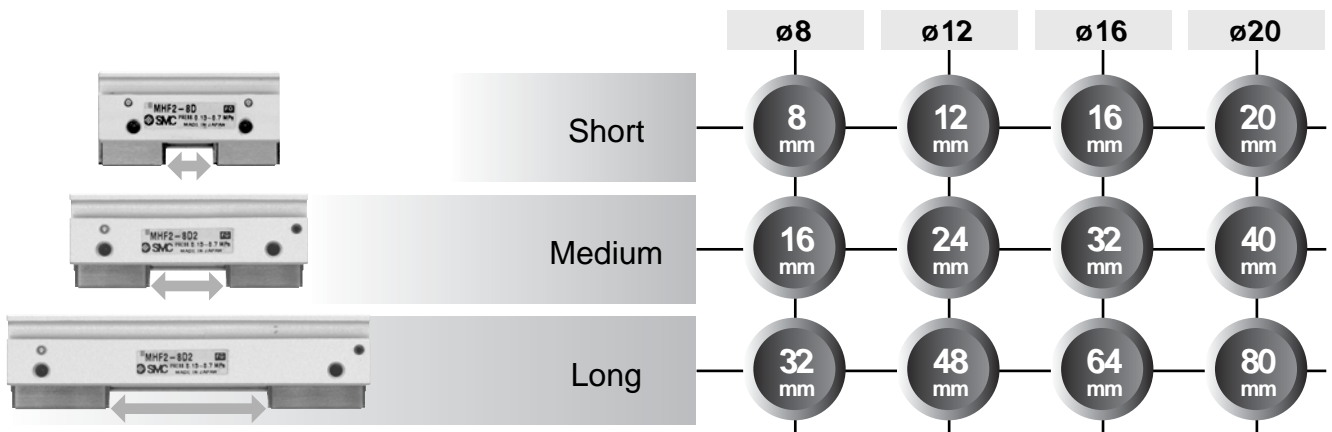

### Improved mounting repeatability

With positioning pin holes

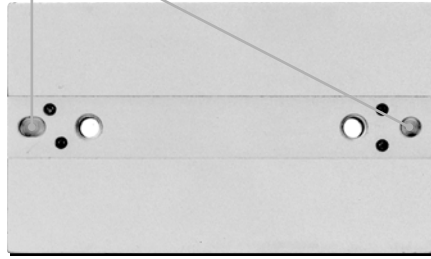

Auto switches can be mounted on both sides.

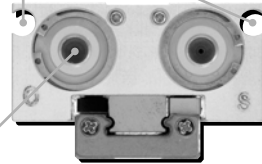

### Piping is available from 2 directions

Piping port position can be specified using a part number.

### Linear guide provides:

High precision and high rigidity with martensitic stainless steel

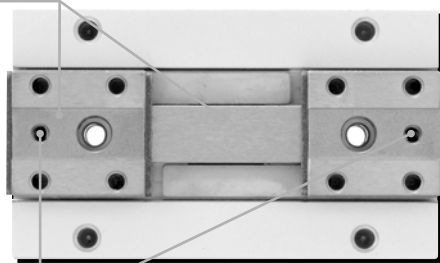

### Easy positioning for mounting attachments

With positioning pin holes

### Centralized wiring and piping are possible.

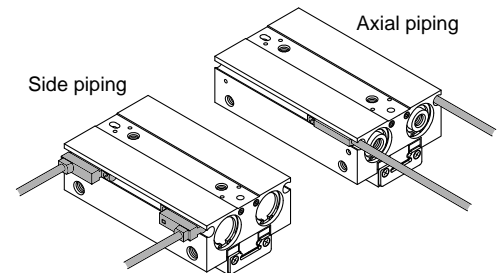

## High degree of mounting flexibility

As no brackets are required, mounting height can be minimized.

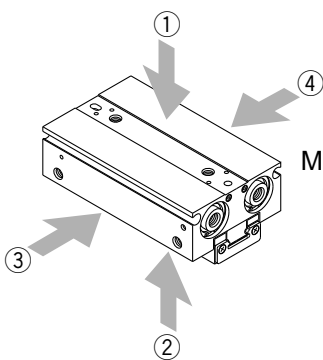

Mounting is possible from 4 directions.

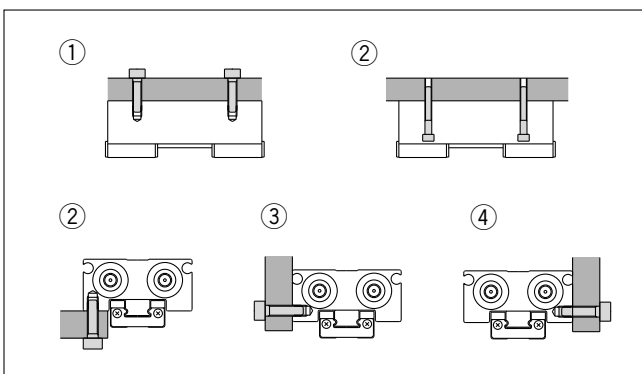

## Strong holding force

Double piston construction achieves compact design with strong holding force.

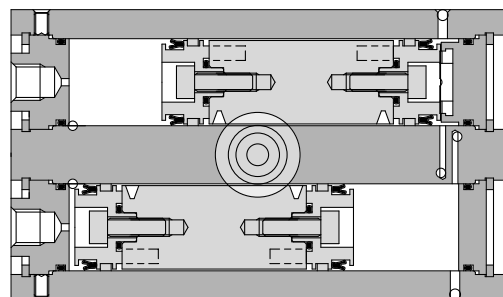

Model	Bore size	Holding force (N)
MHF2-8D□	8	19
MHZ2-10D□	10	11
MHF2-12D□	12	48
MHZ2-20D□	20	42
MHF2-16D□	16	90
MHZ2-25D□	25	65
MHF2-20D□	20	141
MHZ2-32D□	32	158

# Series MHF2 Model Selection

## Model Selection

### Selection procedure

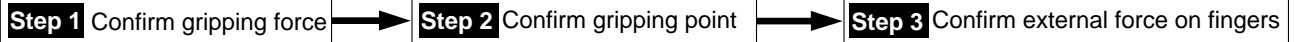

### Step 1 Confirmation of gripping force



Example Work piece weight: **0.15kg**

Gripping method: External gripping

Model selection criteria with respect to work piece weight

- Although differences will exist depending on factors such as shape and the coefficient of friction between attachments and work pieces, select a model which will provide a gripping force 10 to 20 times the weight of the work piece.
- (Note1) Refer to the model selection illustration for more information.
- Furthermore, in cases with high acceleration or impact, etc., it is necessary to allow an even greater margin of safety.

#### Example

When it is desired to set the gripping force at 20 times or more the work piece weight.  
Required gripping force = 0.15 kg x 20 x 9.8 m/s<sup>2</sup> = Approx. 29.4N or more

Length of gripping point : 30mm

Operating pressure : 0.4MPa

#### MHF2-12D □

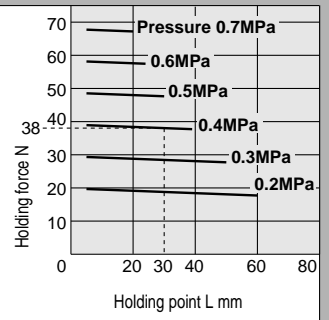

#### Selecting the MHF2-12D □

- The gripping force is obtained from the intersection point of the gripping point distance L=30mm and a pressure of 0.4MPa. Gripping force N=38N
- A gripping force of 38N satisfies the required gripping force of 29.4N. Therefore, the selection of MHF2-12D is appropriate.

### Model selection illustration

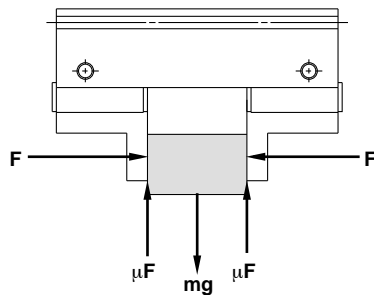

#### Gripping force at least 10 to 20 times the work piece weight

The "10 to 20 times or more of the work piece weight" recommended by SMC is calculated with the safety margin of a = 4, which allows for impacts that occur during normal transportation, etc.

When □ = 0.2	When □ = 0.1
$F = \frac{mg}{2 \times 0.2} \times 4$	$F = \frac{mg}{2 \times 0.1} \times 4$
$= 10 \times mg$	$= 20 \times mg$

10 x work piece weight

20 x work piece weight

When gripping a work piece as in the figure to the left and with the following definitions,

F : Gripping force (N)

□ : Coefficient of friction between attachments and work piece

m : Work piece mass (kg)

g : Gravitational acceleration (= 9.8m/s<sup>2</sup>)

mg : Work piece weight (N)

the conditions under which the work piece will not drop are

$$2 \square F > mg$$

Number of fingers

and therefore,

$$F > \frac{mg}{2 \times \square}$$

With "a" as the safety margin, F is determined as follows:

$$F = \frac{mg}{2 \times \square} \times a$$

(Note) □ Even in cases where the coefficient of friction is greater than □ = 0.2, for safety reasons, SMC recommends selecting a gripping force which is at least 10 to 20 times the work piece weight.

□ If is necessary to allow a greater safety margin for high accelerations and strong impacts, etc.

## Step 1 Effective gripping force: Series MHF2

- Expressing the effective gripping force  
The effective gripping force shown in the graphs to the right is expressed as  $F$ , which is the thrust of one finger when both fingers and attachments are in full contact with the work piece as shown in the figure below.

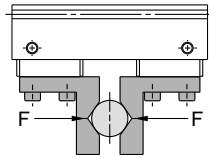

External gripping

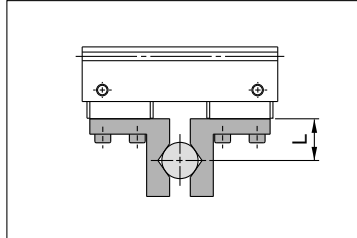

Internal gripping

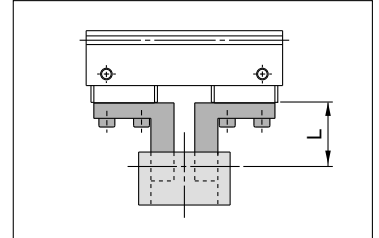

MHF2-8D

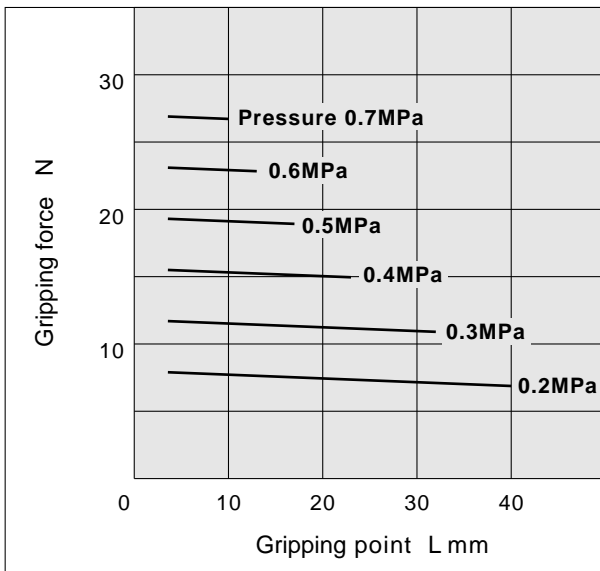

MHF2-12D

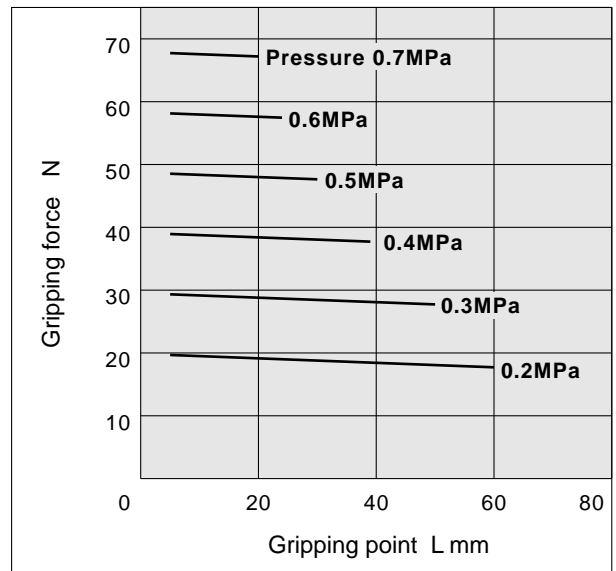

MHF2-16D

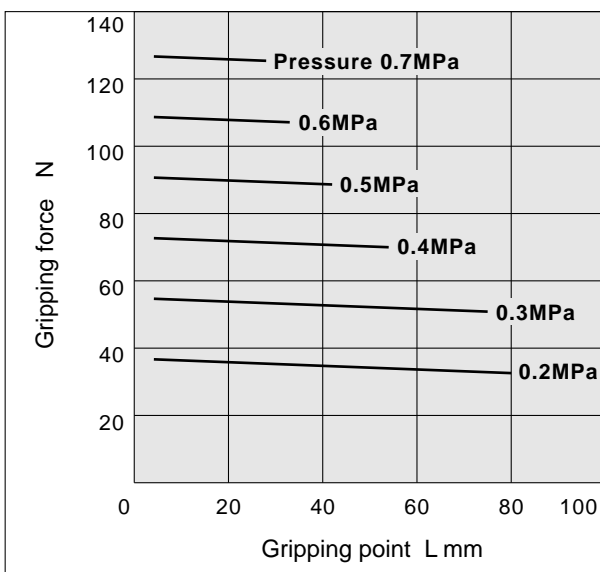

MHF2-20D

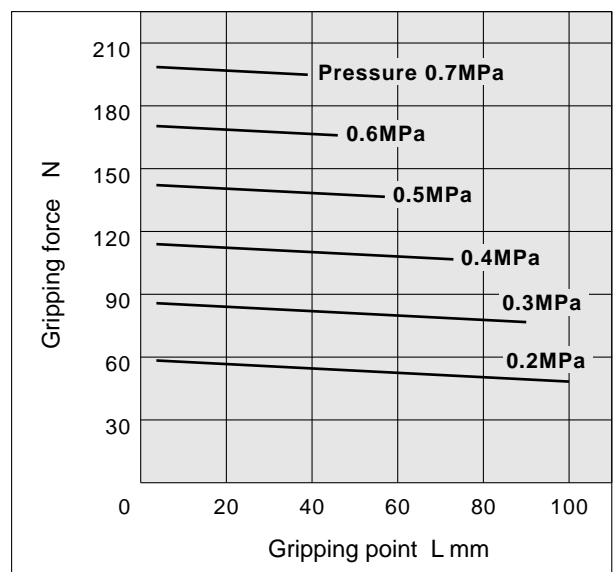

# Series MHF2

## Model Selection

### Step 2 Effective gripping force: Series MHF2

#### External gripping

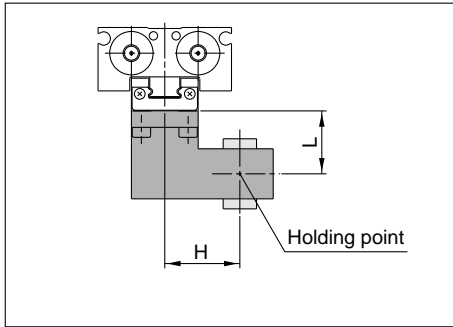

#### Internal gripping

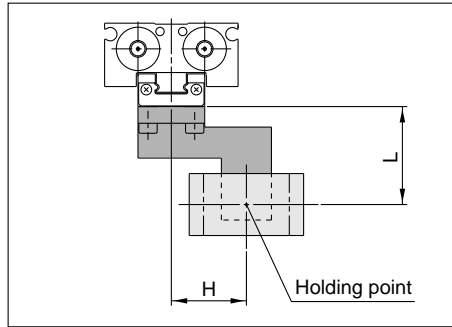

- The air gripper should be operated so that the amount of overhang "H" will stay within the range given in the graphs below.
- If the work piece gripping point goes beyond the range limits, this will have an adverse effect on the life of the air gripper.

**MHF2-8D** □

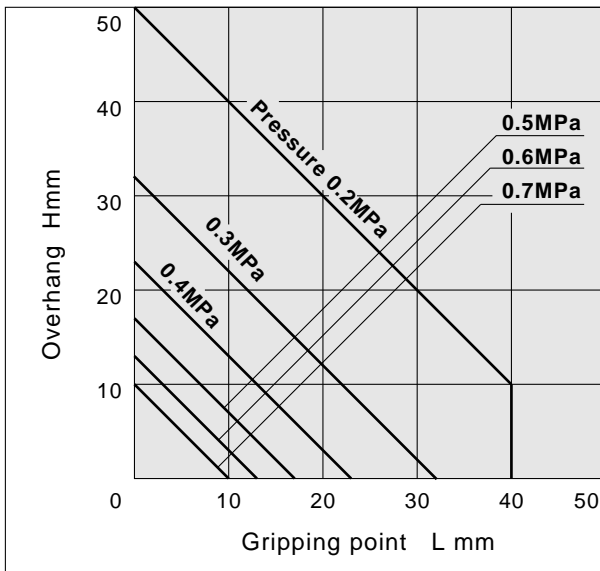

**MHF2-12D** □

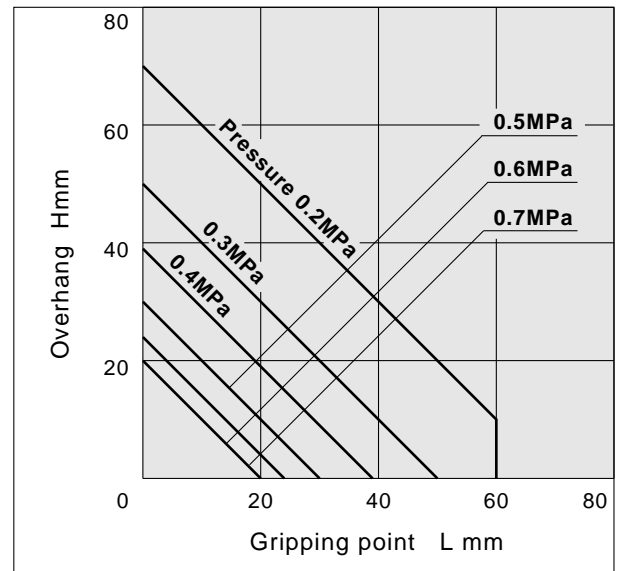

**MHF2-16D** □

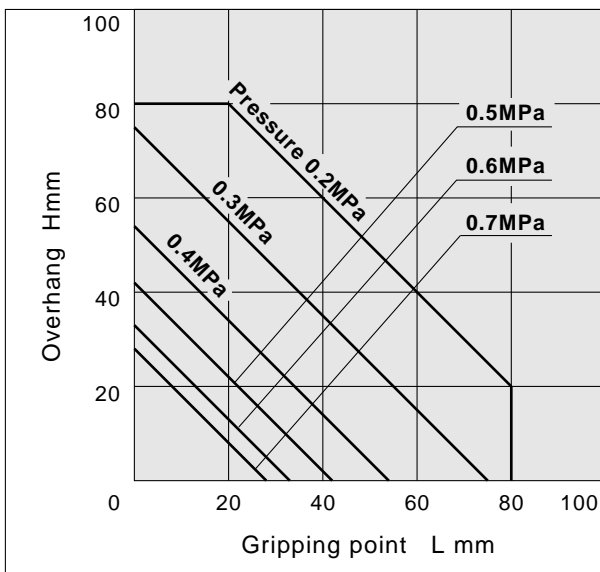

**MHF2-20D** □

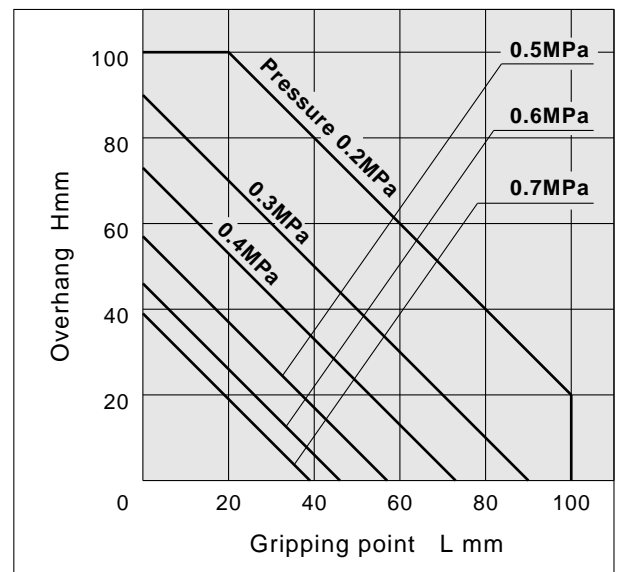

## Step 3 Confirmation of external force on fingers: Series MHF2

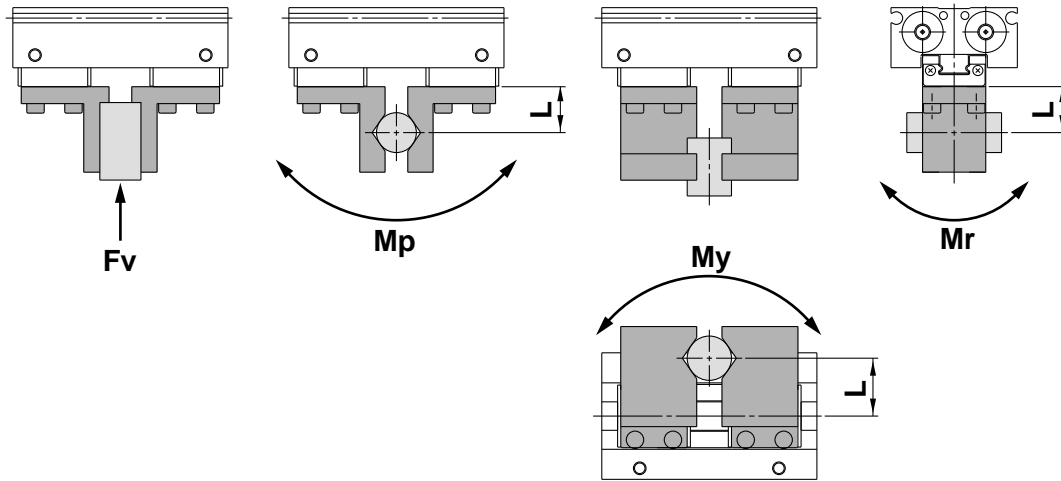

L: Distance to the point at which the load is applied (mm)

Model	Allowable vertical load <b>Fv (N)</b>	Maximum allowable moment		
		Pitch moment <b>Mp (N·m)</b>	Yaw moment <b>My (N·m)</b>	Roll moment <b>Mr (N·m)</b>
<b>MHF2-8D</b> □	58	0.26	0.26	0.53
<b>MHF2-12D</b> □	98	0.68	0.68	1.4
<b>MHF2-16D</b> □	176	1.4	1.4	2.8
<b>MHF2-20D</b> □	294	2	2	4

Note) The load and moment values in the table indicate static values.

Calculation of allowable external force (when moment load is applied)	Calculation example
$\text{Allowable load } F(\text{N}) = \frac{M(\text{Maximum allowable moment})(\text{N}\cdot\text{m})}{L \times 10^{-3}}$ <p style="text-align: center;">□ (□Unit converted invariable number)</p>	<p>When a load <math>f = 10\text{N}</math> is operating, which applies pitch moment to point <math>L = 30\text{ mm}</math> from the end of the MHF2-12D finger.</p> $\text{Allowable load } F = \frac{0.68}{30 \times 10^{-3}}$ $= 22.7 (\text{N})$ <p><b>Load <math>f = 10 (\text{N}) &lt; 22.7 (\text{N})</math></b></p> <p>Therefore, it can be used.</p>

# Low Profile Air Gripper

## Series *MHF2*

ø8, ø12, ø16, ø20

### How to Order

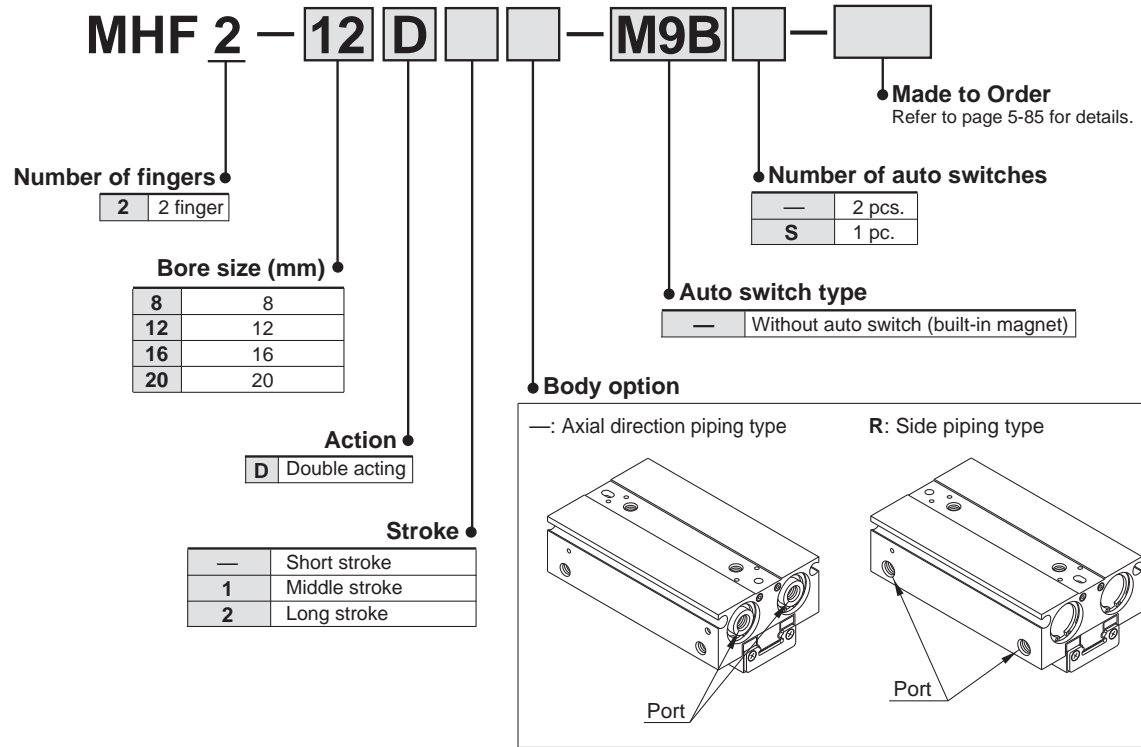

### Applicable Auto Switches

Refer to auto switches guide for further information.

Type	Special function	Electrical entry	Indicator light	Wiring (Output)	Load voltage		Auto switch model		Lead wire length (m)*				Pre-wired connector	Applicable load		
					DC	AC	Electrical entry direction		0.5 (—)	1 (M)	3 (L)	5 (Z)		IC circuit	Relay, PLC	
							Perpendicular	In-line								
Solid state auto switch	—	Grommet	Yes	3-wire (NPN)	5 V, 12 V	—	M9NV	M9N	●	●	●	○	○	IC circuit	Relay, PLC	
				3-wire (PNP)					●	●	●	○	○			
				2-wire	12 V		●	●	●	○	○	—				
				3-wire (NPN)	5 V, 12 V		●	●	●	○	○	IC circuit				
	3-wire (PNP)			●			●	●	○	○	—					
	Diagnostic indication (2-colour indicator)			2-wire	3-wire (NPN)		12 V	●	●	●	○	○	—			
					3-wire (PNP)			●	●	●	○	○	—			
				Water resistant (2-colour indicator)	3-wire (NPN)		5 V, 12 V	M9NAV**	M9NA**	○	○	●	○	○		IC circuit
					3-wire (PNP)			M9PAV**	M9PA**	○	○	●	○	○		IC circuit
					2-wire		12 V	M9BAV**	M9BA**	○	○	●	○	○		—
2-wire		12 V	○		○	●	○	○	○	○	—					

\*\* Water resistant type auto switches can be mounted on the above models, but in such case SMC cannot guarantee water resistance.

\* Lead wire length symbols: 0.5 m ..... — (Example) M9NW  
 1 m ..... M (Example) M9NWM  
 3 m ..... L (Example) M9NWL  
 5 m ..... Z (Example) M9NWZ

\* Auto switches marked with "○" are made to order specification.

Note) When using the 2-colour indicator type, please make the setting so that the indicator is lit in red to ensure the detection at the proper position of the air gripper.





## Symbol

Double acting:  
Internal grip

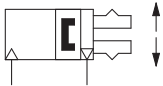

Double acting:  
External grip

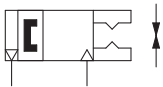

**Made to Order: Individual Specifications**

Symbol	Specifications/Description
-X83	With an adjustable opening/closing finger positioning



**Made to Order**

Symbol	Specifications/Description
-X4	Heat resistance (100°C)
-X5	Fluororubber seal
-X50	Without magnet
-X53	EPDM seal/Fluorine grease
-X63	Fluorine grease
-X79	Grease for food processing machines, Fluorine grease
-X79A	Grease for food processing machines
-X81A	Anti-corrosive treatment of finger
-X81B	Anti-corrosive treatment of finger, guide and joint
-X83	With an adjustable opening/closing finger positioning

## Moisture Control Tube Series IDK



When operating an actuator with a small diameter and a short stroke at a high frequency, the dew condensation (water droplet) may occur inside the piping depending on the conditions.

Simply connecting the moisture control tube to the actuator will prevent dew condensation from occurring. For details, refer to [the IDK series in the Best Pneumatics No. 6](#).

## Specifications

Fluid		Air
Operating pressure		ø8: 0.15 to 0.7 MPa
		ø12 to 20: 0.1 to 0.7 MPa
Ambient and fluid temperature		-10 to 60°C (with no condensation)
Repeatability		±0.05 mm <sup>Note1)</sup>
Maximum operating frequency	Short stroke	120 c.p.m.
	Middle stroke	120 c.p.m.
	Long stroke	60 c.p.m.
Lubrication		Not required
Action		Double acting
Auto switch (Optional) <sup>Note2)</sup>		Solid state switch (3-wire, 2-wire)

Note 1) This is the value when no offset load is applied to the finger.

When an offset load is applied to the finger, the maximum value is ±0.15 mm due to the influence of backlash of the rack and pinion.

Note 2) Refer to page 6-15 for further information on auto switch specifications.

## Model

Action	Model	Cylinder bore (mm)	Gripping force <sup>Note1)</sup>		Opening /closing stroke (Both sides) mm	Weight <sup>Note2)</sup> g	Unobstructed capacity (cm <sup>3</sup> )	
			Effective holding force per finger N				Finger open side	Finger close side
Double acting	MHF2-8D	8	19		8	65	0.7	0.6
	MHF2-8D1				16	85	1.1	1.0
	MHF2-8D2				32	120	2.0	1.9
	MHF2-12D	12	48		12	155	1.9	1.6
	MHF2-12D1				24	190	3.3	3.0
	MHF2-12D2				48	275	6.1	5.8
	MHF2-16D	16	90		16	350	4.9	4.1
	MHF2-16D1				32	445	8.2	7.4
	MHF2-16D2				64	650	14.9	14.0
	MHF2-20D	20	141		20	645	8.7	7.3
	MHF2-20D1				40	850	15.1	13.7
	MHF2-20D2				80	1,225	28.0	26.6

Note 1) At the pressure of 0.5 MPa, when holding point L is 20 mm.

Note 2) Excluding the auto switch weight

## Construction

### MHF2-8D, MHF2-8D1

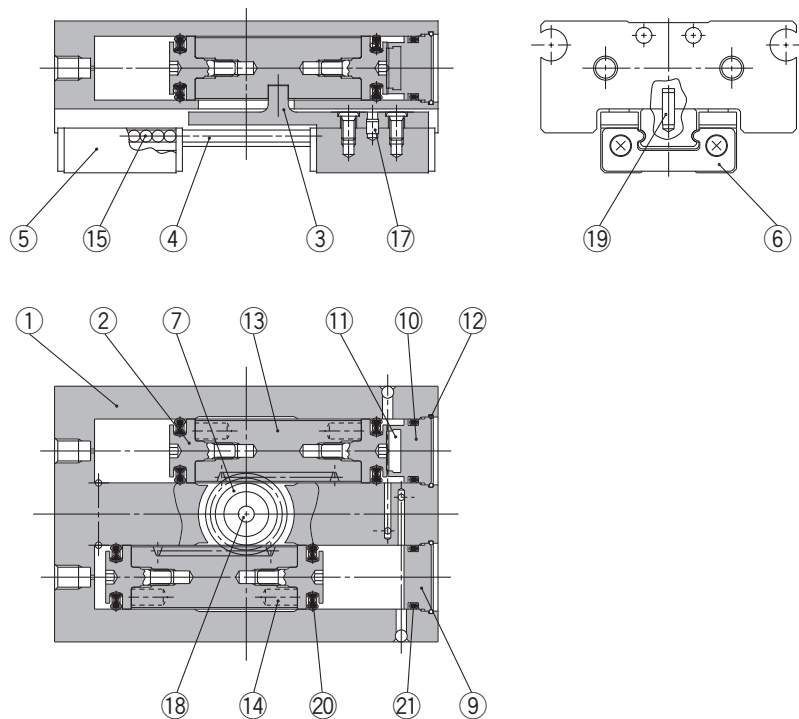

### MHF2-8D2

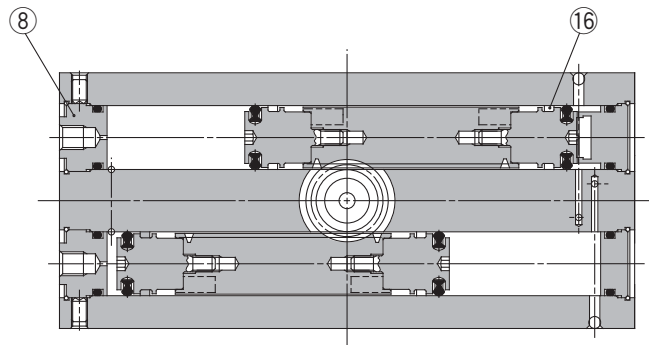

#### Parts list

No.	Description	Material	Note
1	Body	Aluminium alloy	Hard anodized
2	Piston	Stainless steel	
3	Joint	Stainless steel	Heat treatment
4	Guide rail	Stainless steel	Heat treatment
5	Finger	Stainless steel	Heat treatment
6	Roller stopper	Stainless steel	
7	Pinion	Carbon steel	Nit riding
8	Cap A	Aluminium alloy	Clear anodized
9	Cap B	Aluminium alloy	Clear anodized
10	Cap C	Aluminium alloy	Clear anodized

#### Parts list

No.	Description	Material	Note
11	Head damper	Urethane rubber	
12	Clip	Stainless steel wire	
13	Rack	Stainless steel	Nit riding
14	Magnet	Rare earth magnet	Nickel plated
15	Steel balls	High carbon chromium bearing steel	
16	Wear ring	Synthetic resin	
17	Roller	High carbon chromium bearing steel	
18	Needle roller	High carbon chromium bearing steel	
19	Parallel pin	Stainless steel	
20	Piston seal	NBR	
21	Gasket	NBR	

#### Replaceable parts list

Description	Kit No.			Contents
	MHF2-8D	MHF2-8D1	MHF2-8D2	
Seal kit	MHF8-PS	MHF8-PS	MHF8-PS-2	12, 20, 21
Finger assembly	MHF-A0802	MHF-A0802-1	MHF-A0802-2	3, 4, 5, 6, 15, 17, 19 Mounting screw

#### Bolts for body through hole mounting

Part No.	Number of pieces	
	MHF2-8D	MHF2-8D1
MHF-B08	MHF2-8D	2 pieces/unit
	MHF2-8D1	2 pieces/unit
	MHF2-8D2	4 pieces/unit

#### Replacement part/Grease pack part no.:

Guide unit: GR-S-010 (10 g)  
Cylinder unit: GR-L-005 (5 g)

\*The bolts for body through hole mounting are attached to the product. They are also provided at an order of 1 piece or more with the above part

## Construction

### MHF2-12D□ to 20D□

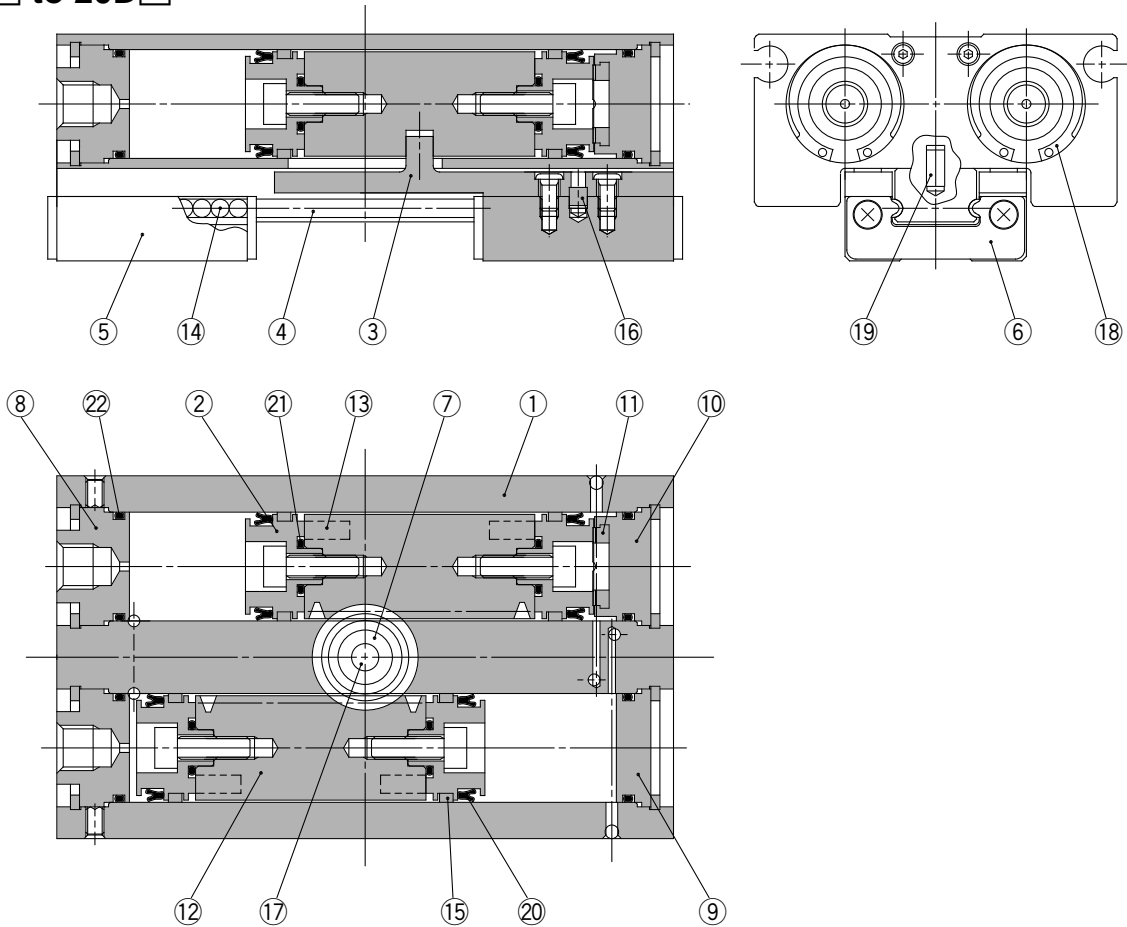

#### Parts list

No.	Description	Material	Note
1	Body	Aluminium alloy	Hard anodized
2	Piston	Aluminium alloy	Clear anodized
3	Joint	Stainless steel	Heat treatment
4	Guide rail	Stainless steel	Heat treatment
5	Finger	Stainless steel	Heat treatment
6	Roller stopper	Stainless steel	
7	Pinion	Carbon steel	Nit riding
8	Cap A	Aluminium alloy	Clear anodized
9	Cap B	Aluminium alloy	Clear anodized
10	Cap C	Aluminium alloy	Clear anodized
11	Head damper	Urethane rubber	
12	Rack	Stainless steel	Nit riding

#### Parts list

No.	Description	Material	Note
13	Magnet	Tare earth magnet	Nickel plated
14	Steel balls	High carbon chromium bearing steel	
15	Wear ring	Synthetic resin	
16	ø12: Roller	High carbon chromium bearing steel	
	ø16 to 20: Parallel pin	Stainless steel	
17	Needle roller	High carbon chromium bearing steel	
18	ø12: R shape snap ring	Carbon steel	Nickel plated
	ø16 to 20: C type snap ring		
19	Parallel pin	Stainless steel	
20	Piston seal	NBR	
21	Gasket	NBR	
22	Gasket	NBR	

#### Replaceable parts list

Description	Kit No.			Contents
	MHF2-12D	MHF2-12D1	MHF2-12D2	
Seal kit	MHF12-PS	MHF12-PS	MHF12-PS	20, 21, 22
Finger assembly	MHF-A1202	MHF-A1202-1	MHF-A1202-2	3, 4, 5, 6, 14, 16, 19 Mounting screw

Description	Kit No.			Contents
	MHF2-16D	MHF2-16D1	MHF2-16D2	
Seal kit	MHF16-PS	MHF16-PS	MHF16-PS	20, 21, 22
Finger assembly	MHF-A1602	MHF-A1602-1	MHF-A1602-2	3, 4, 5, 6, 14, 16, 19 Mounting screw

Description	Kit No.			Contents
	MHF2-20D	MHF2-20D1	MHF2-20D2	
Seal kit	MHF20-PS	MHF20-PS	MHF20-PS	20, 21, 22
Finger assembly	MHF-A2002	MHF-A2002-1	MHF-A2002-2	3, 4, 5, 6, 14, 16, 19 Mounting screw

#### Bolts for body through hole mounting

Part No.	Number of pieces	
	MHF2-12D	MHF2-12D1
MHF-B12	MHF2-12D	2 pieces/unit
	MHF2-12D1	2 pieces/unit
	MHF2-12D2	4 pieces/unit

□The bolts for body through hole mounting are attached to the product. They are also provided at an order of 1 piece or more with the above part numbers.

□When mounting MHF2-16D□ or MHF2-20D□ with the body through holes, use hexagon socket head screws available on the market.

# Series MHF2

## Dimensions

### MHF2-8D

Scale: 80%

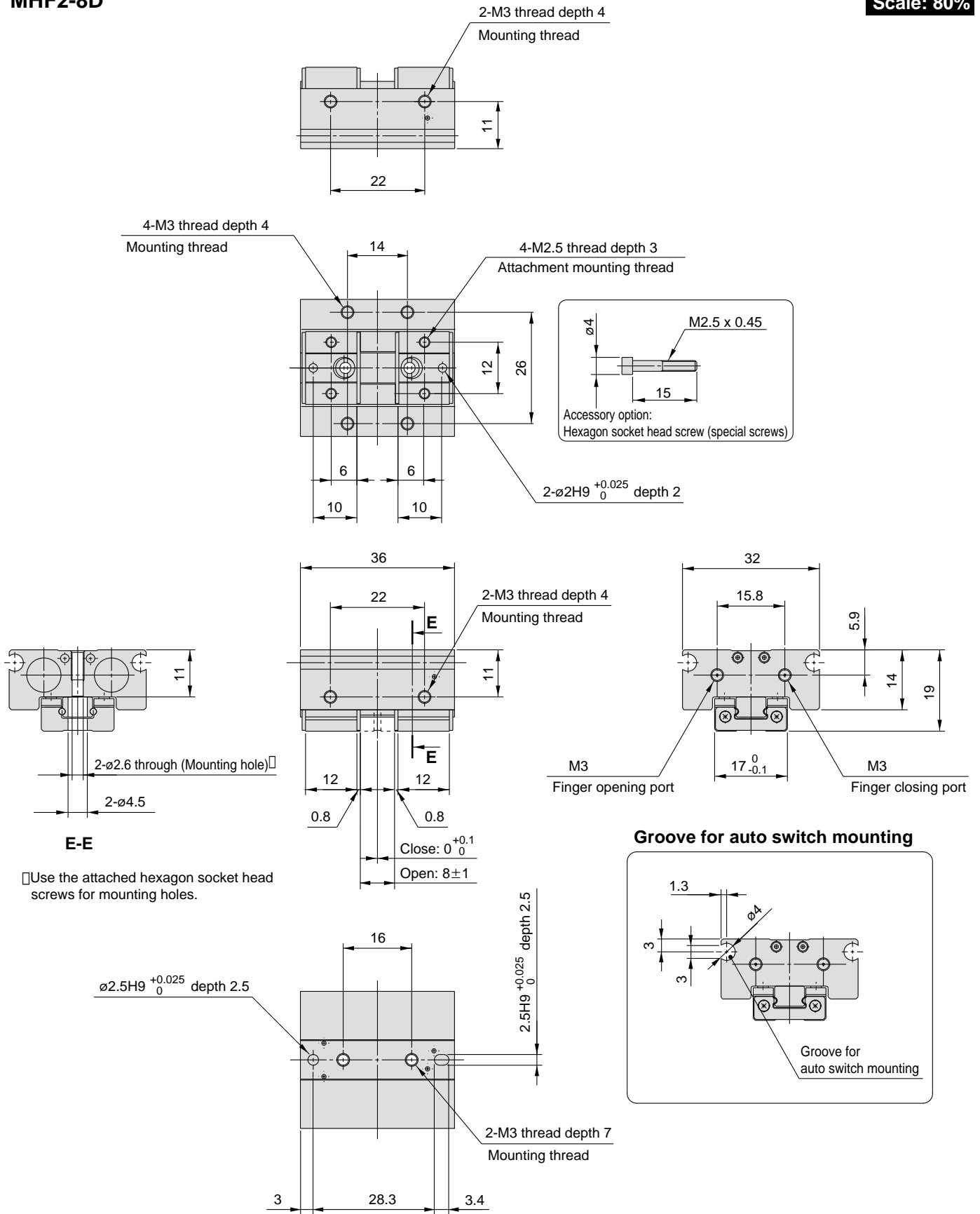

## Dimensions

### MHF2-8D1

Scale: 80%

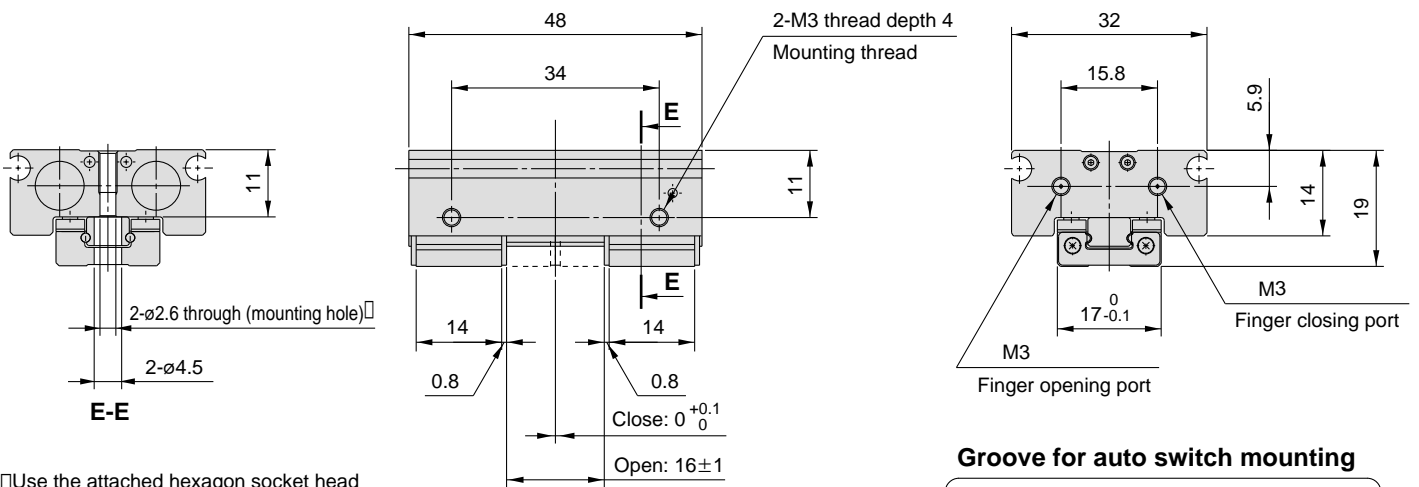
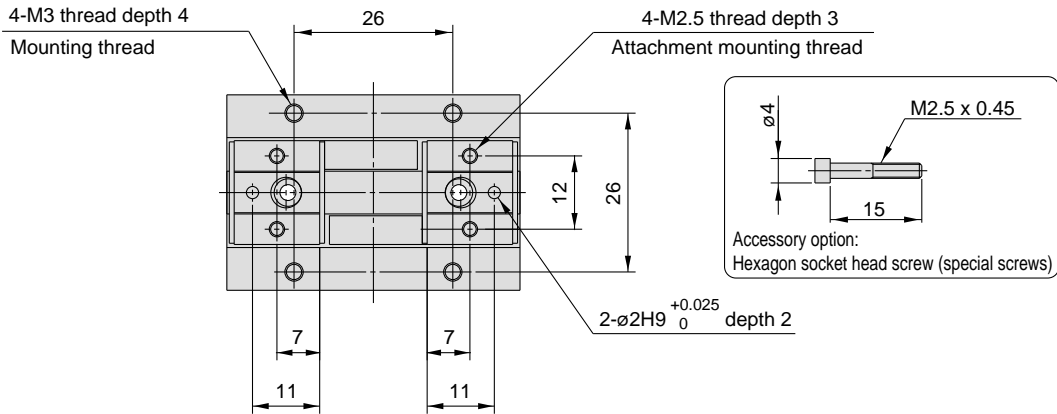
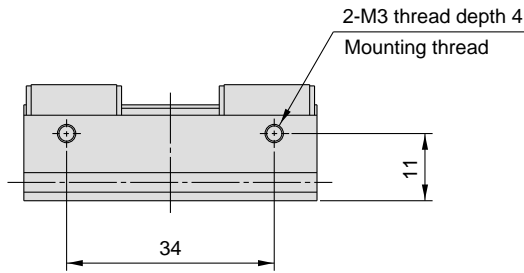

□ Use the attached hexagon socket head screws for mounting holes.

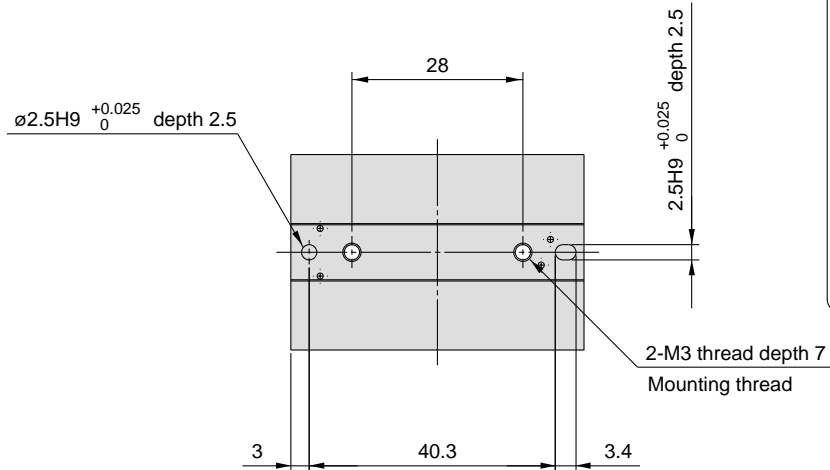

### Groove for auto switch mounting

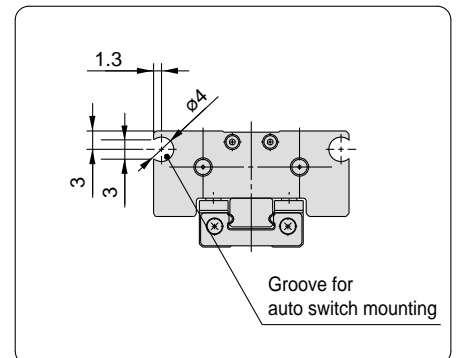



**Dimensions**

**MHF2-12D**

**Scale: 65%**

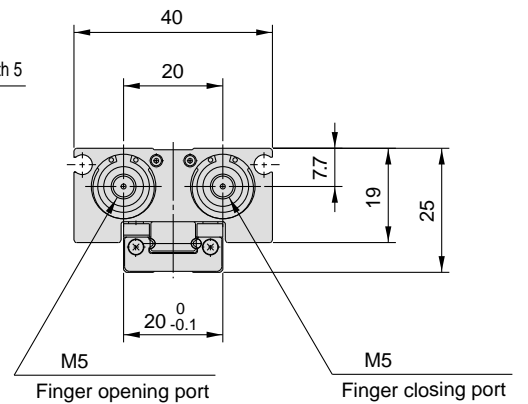
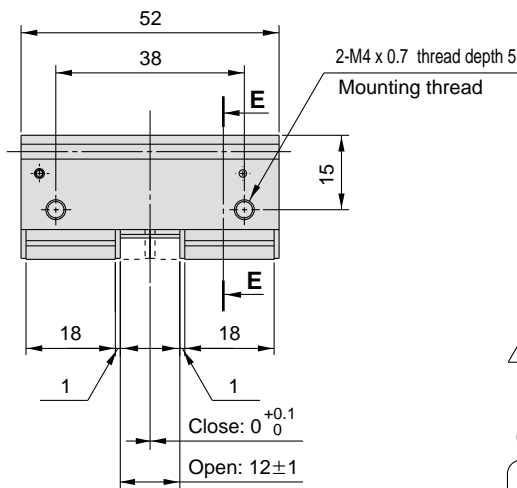
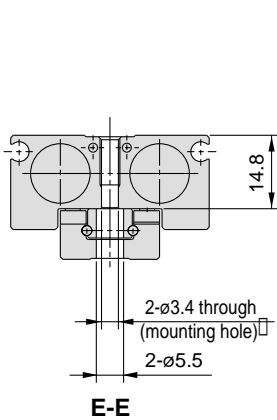
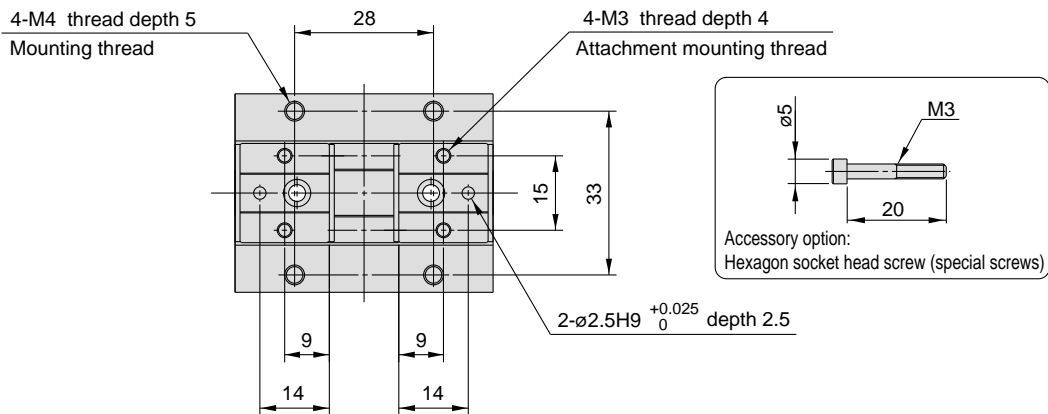
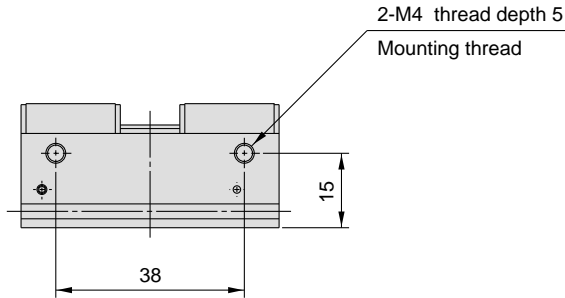

**Groove for auto switch mounting**

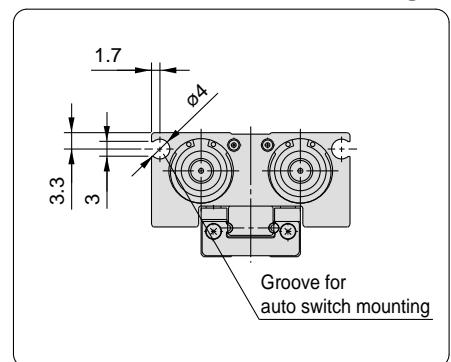

□ Use the attached hexagon socket head screws for mounting holes.

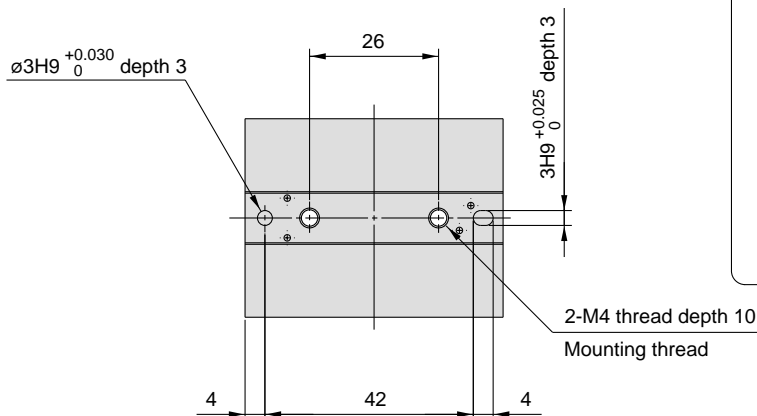

# Series MHF2

## Dimensions

MHF2-12D1

Scale: 65%

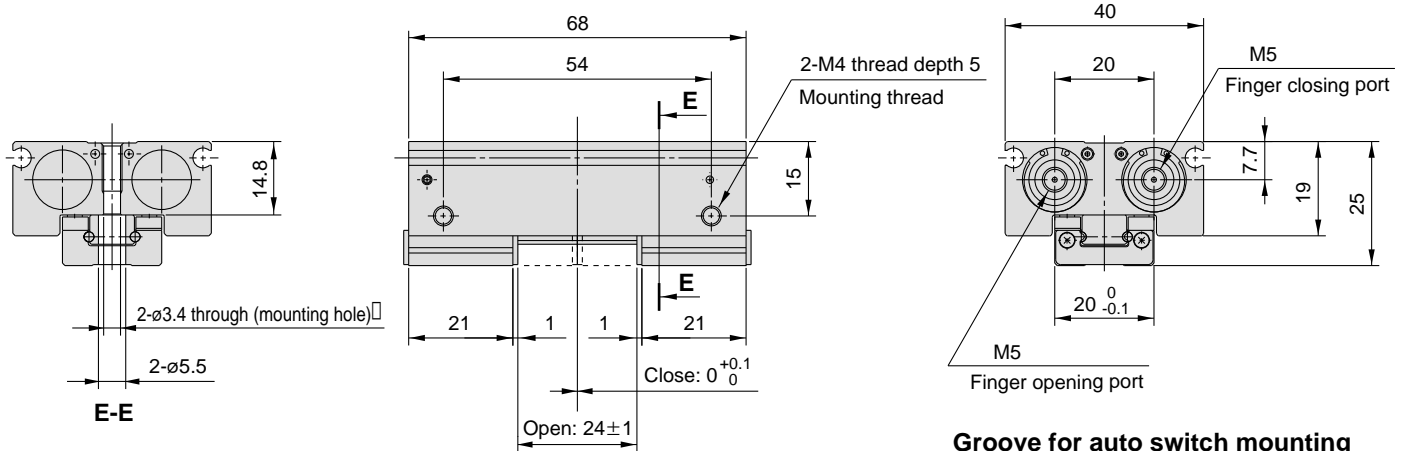
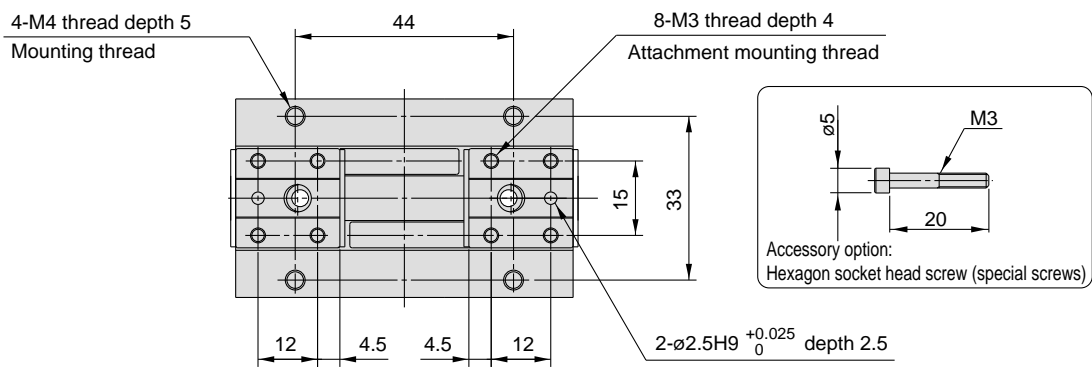
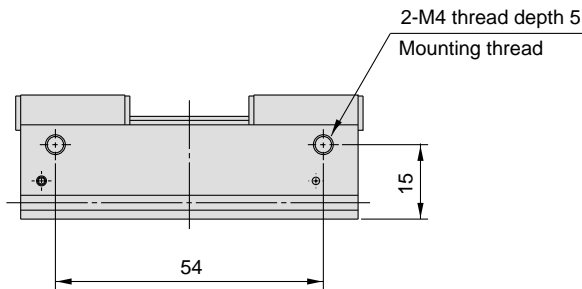

□ Use the attached hexagon socket head screws for mounting holes.

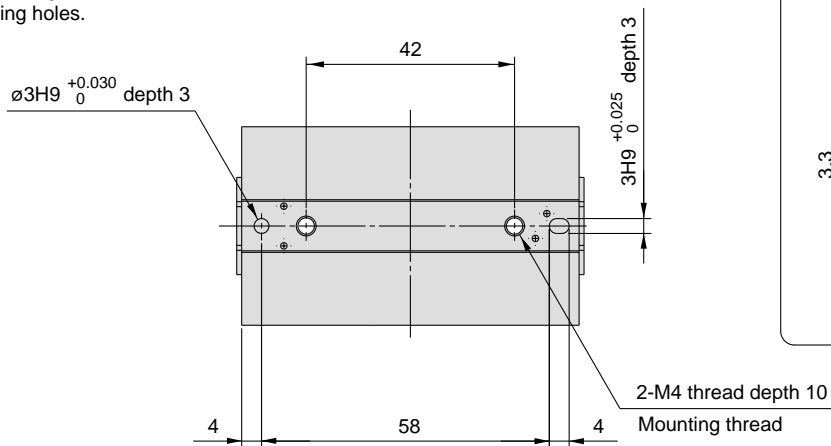

### Groove for auto switch mounting

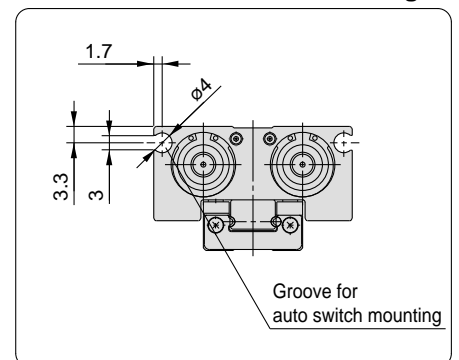



## Dimensions

MHF2-12D2

Scale: 65%

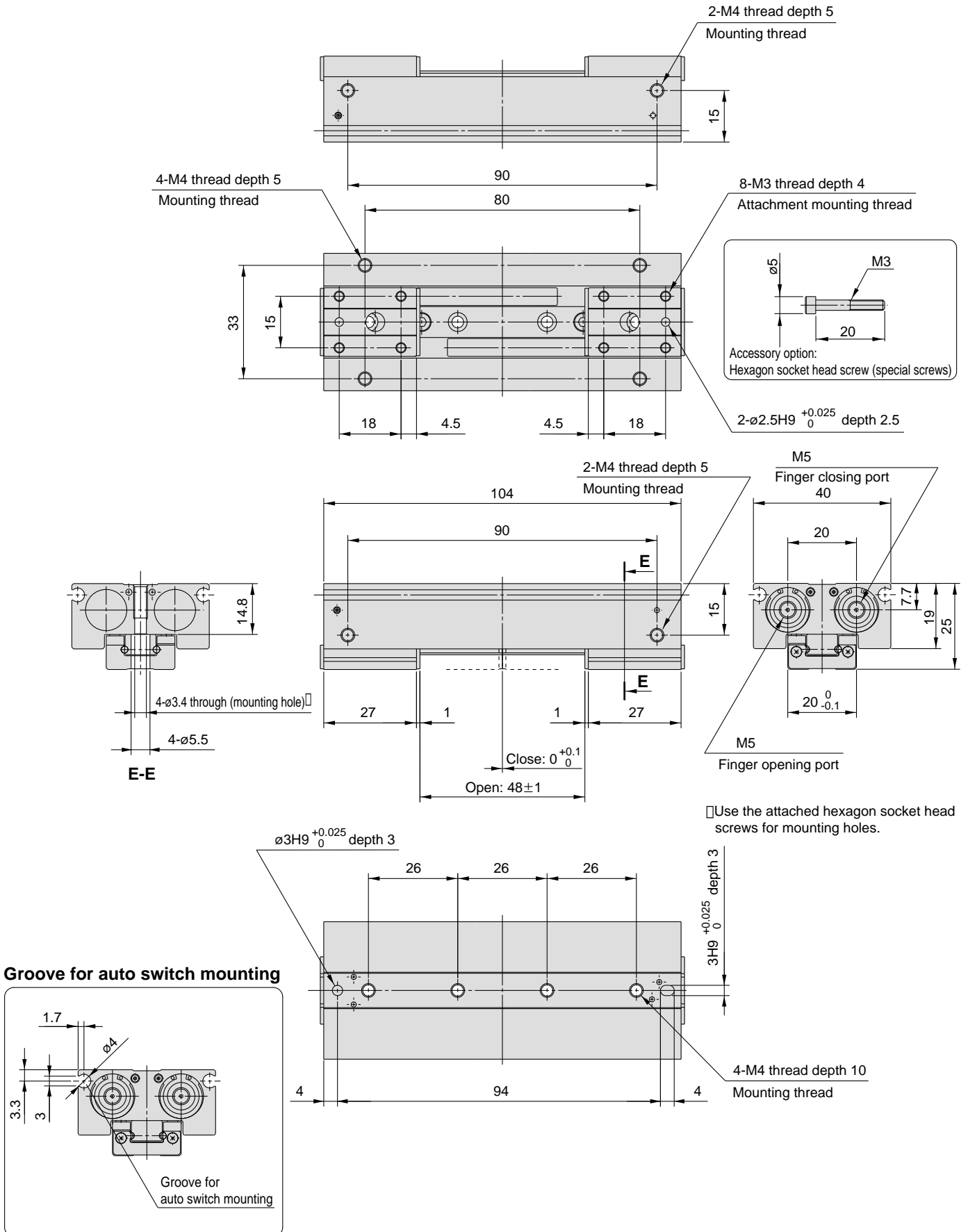

# Series MHF2

## Dimensions

### MHF2-16D

Scale: 50%

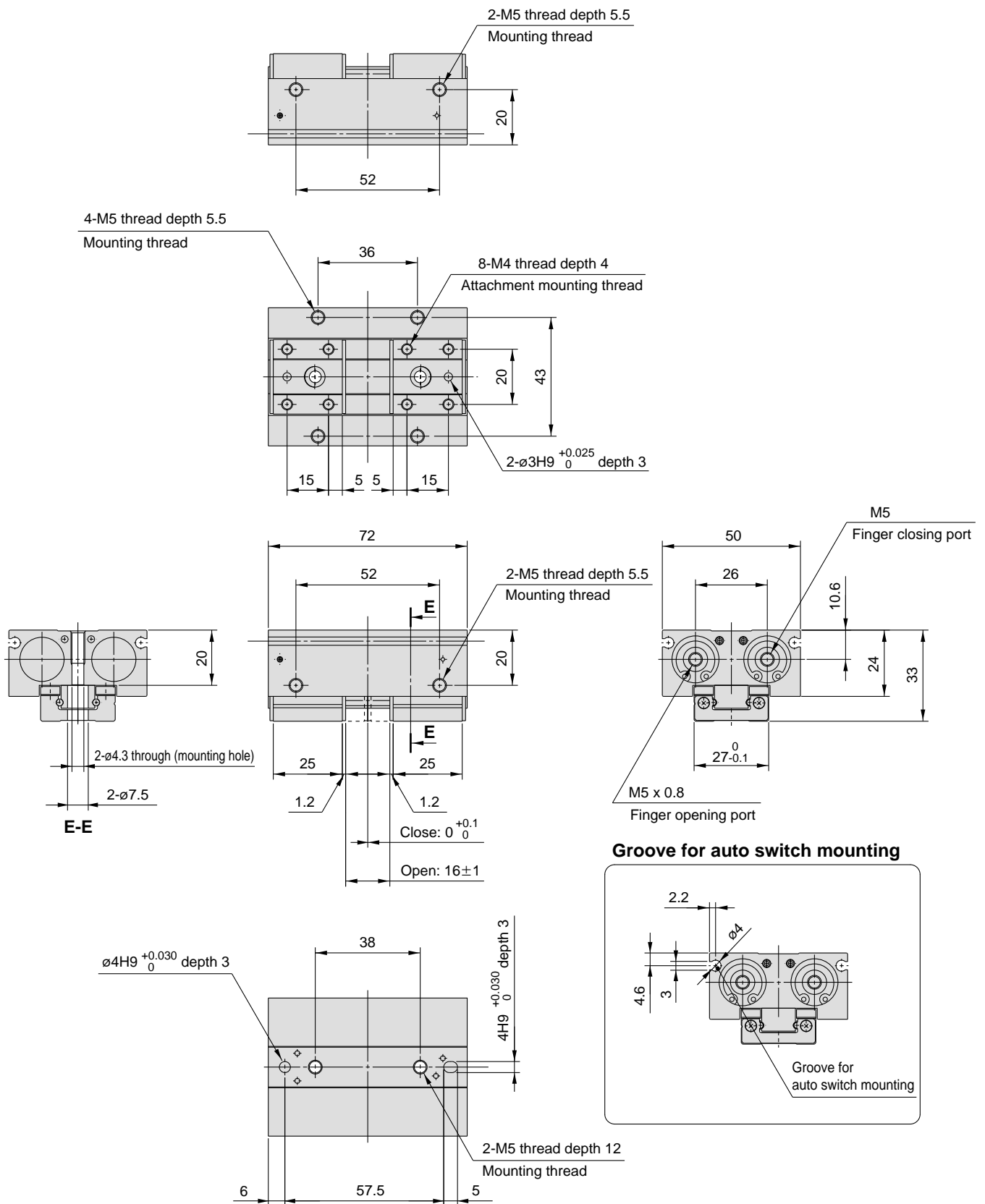

**Dimensions**

**MHF2-16D1**

**Scale: 50%**

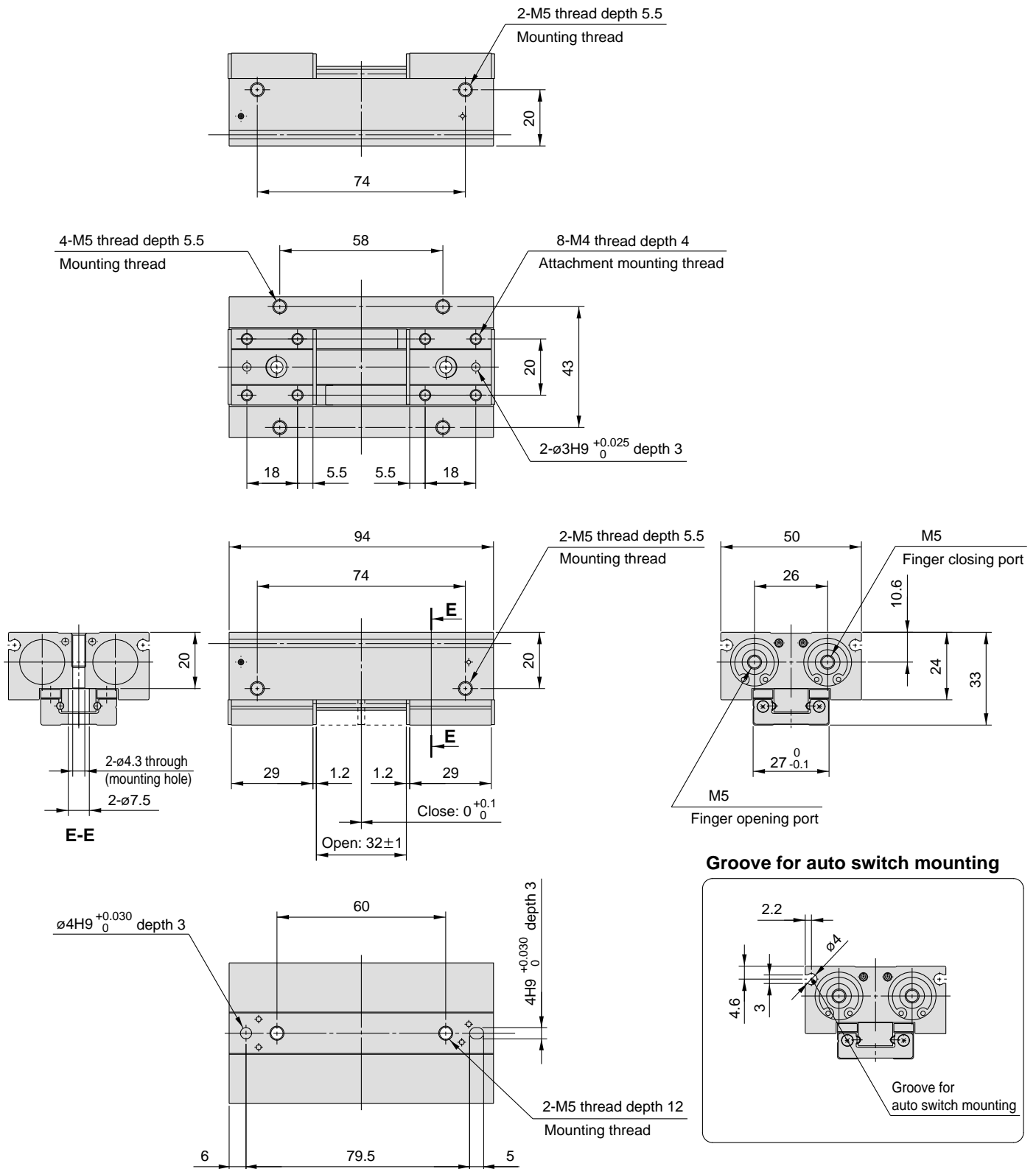

# Series MHF2

## Dimensions

### MHF2-16D2

Scale: 50%

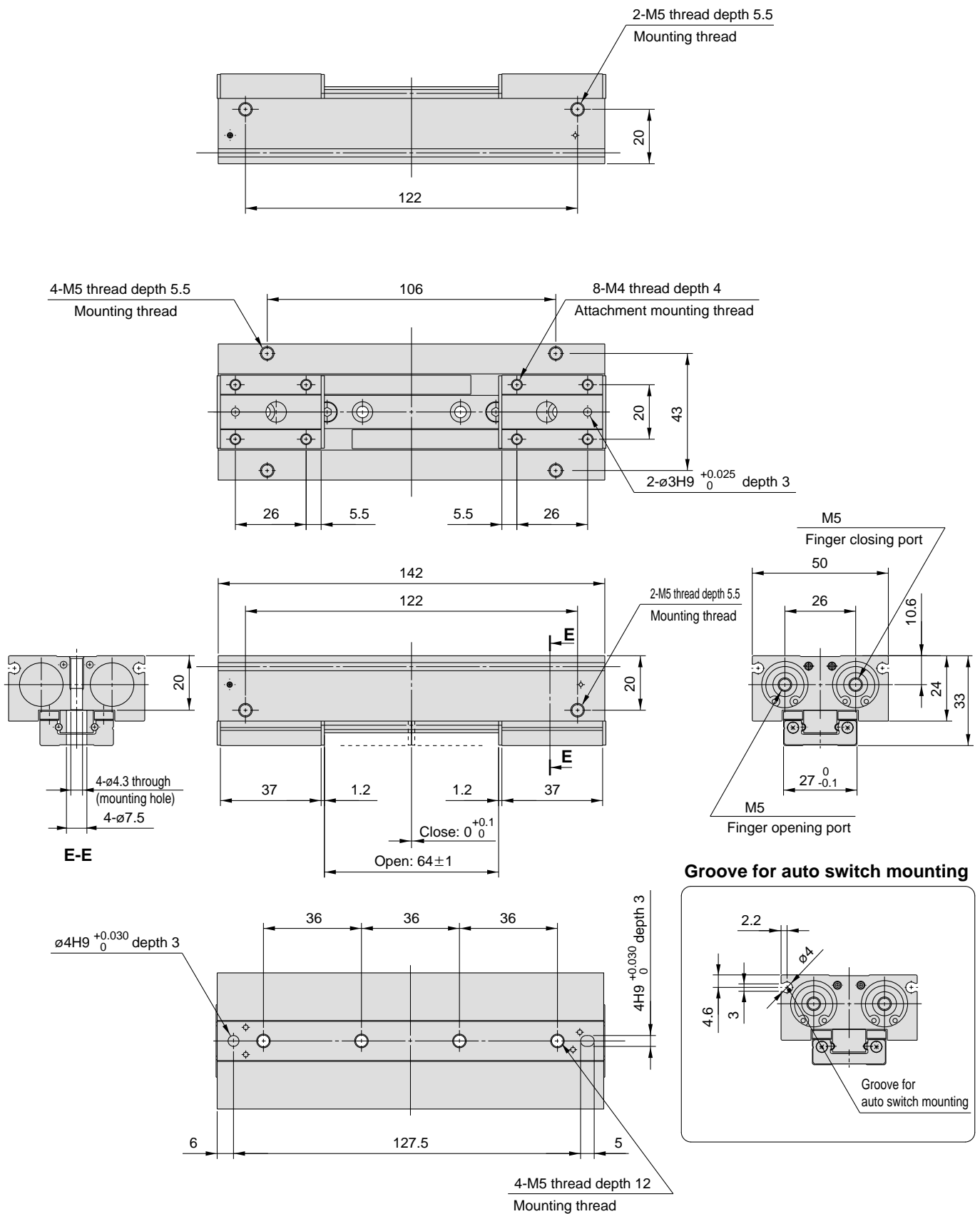

**Dimensions**

**MHF2-20D**

**Scale: 50%**

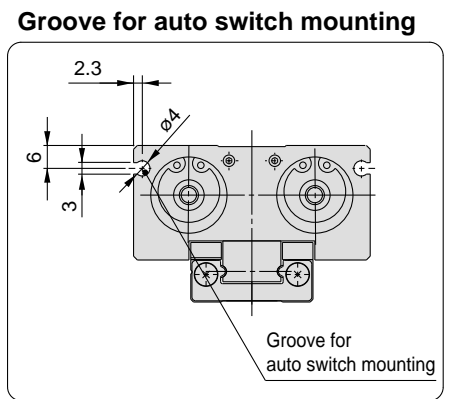
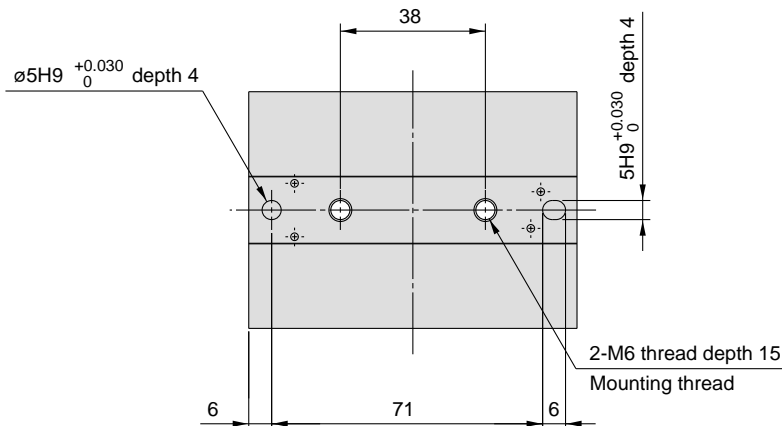
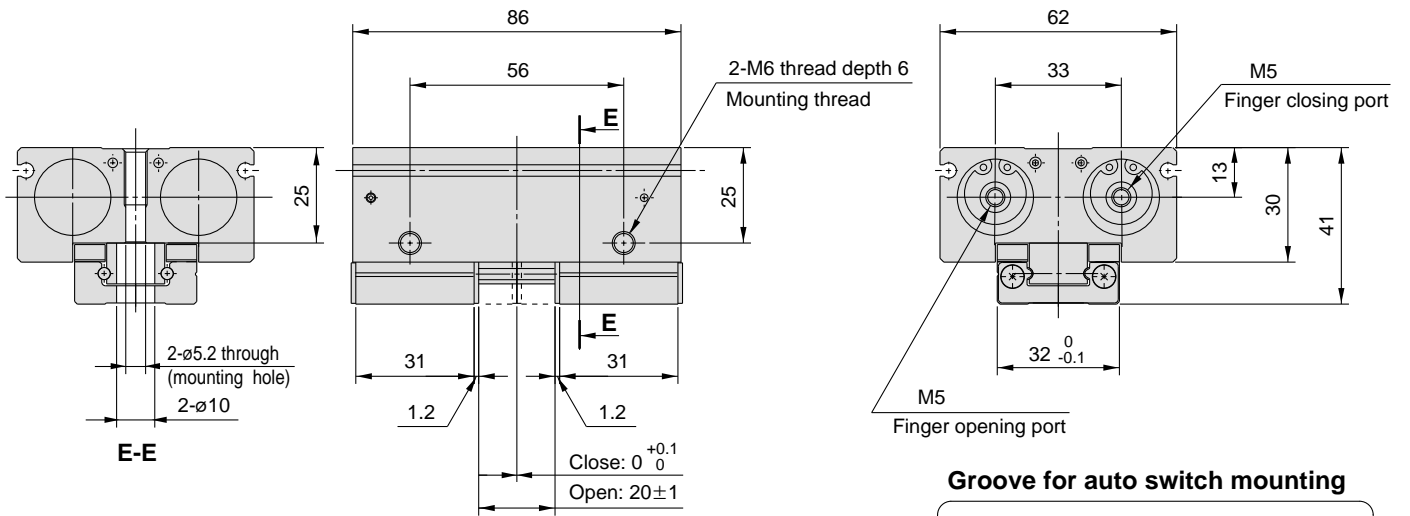
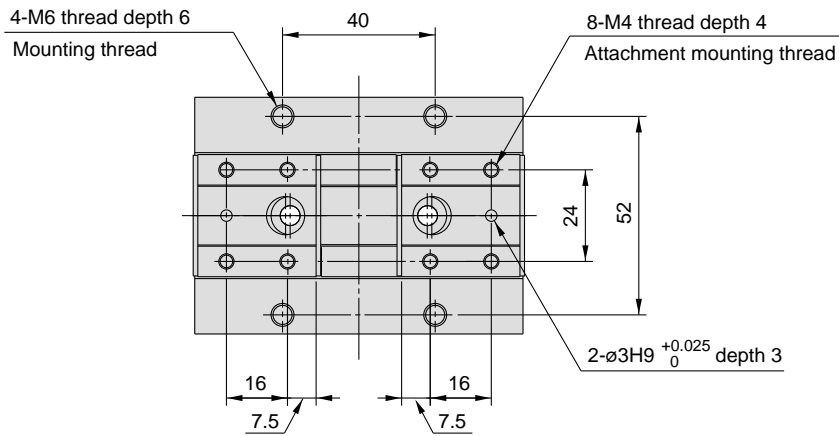
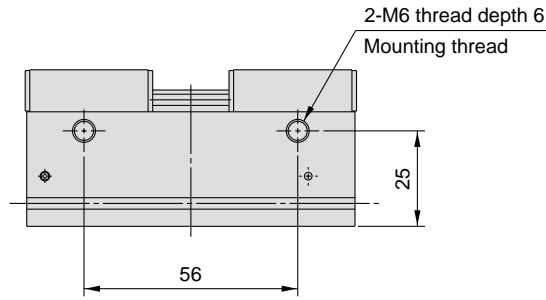

# Series MHF2

## Dimensions

### MHF2-20D1

Scale: 50%

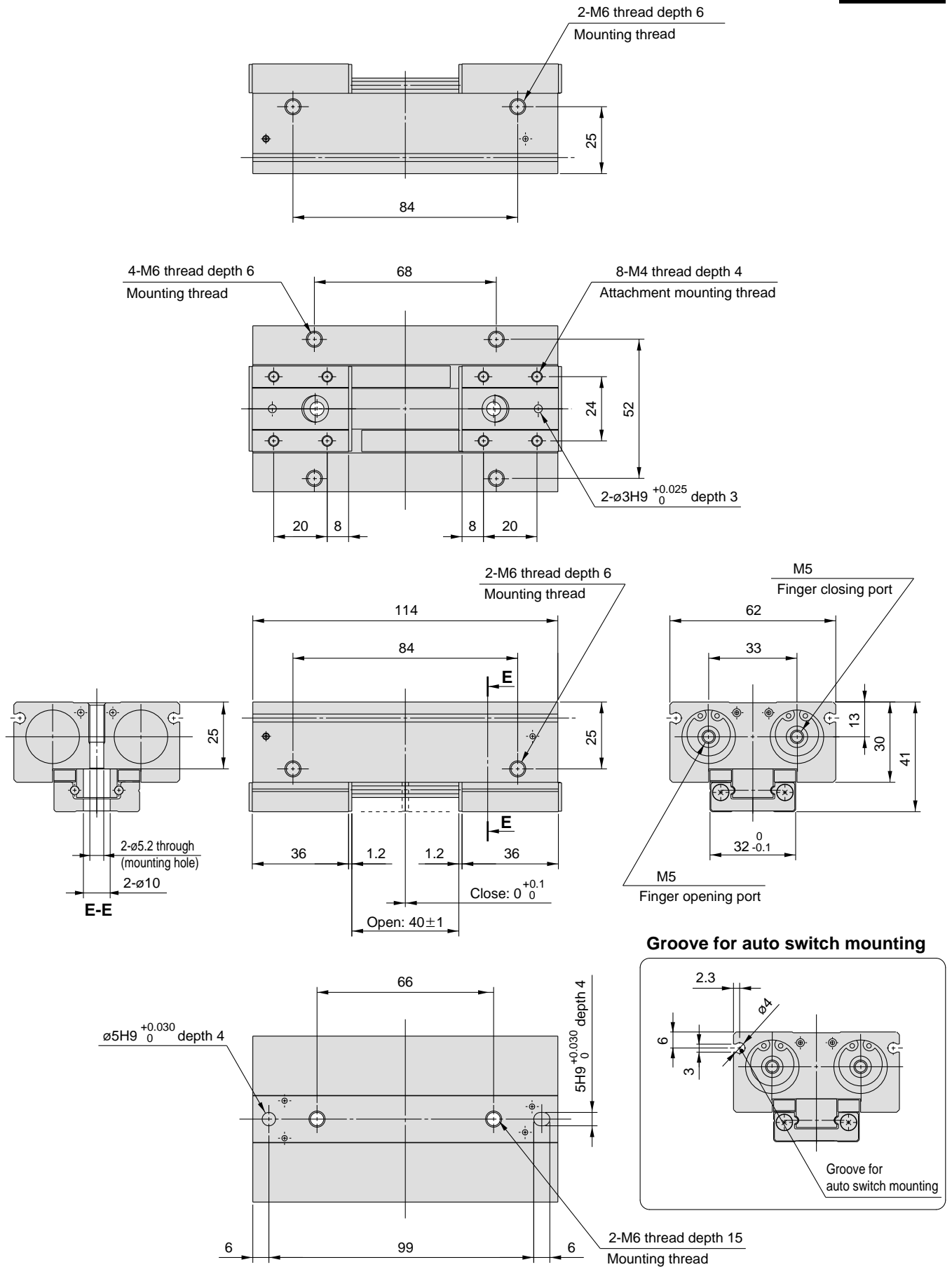

## Dimensions

MHF2-20D2

Scale: 50%

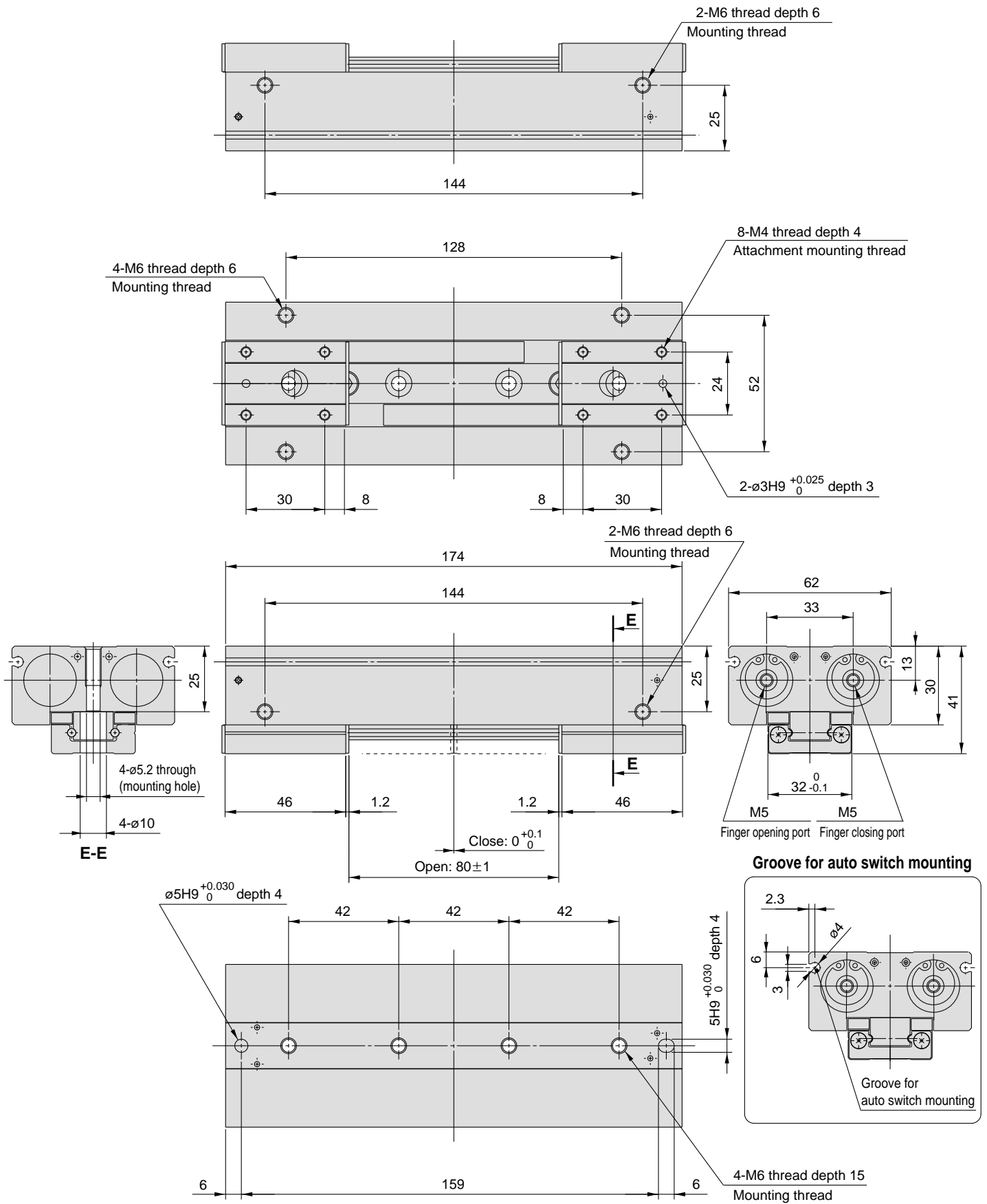

## Series *MFH2*

# Body Option: Side Piping Type

**MHF2-8DR**  
**MHF2-8D1R**

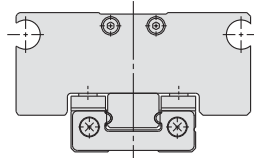

Port side of axial piping type

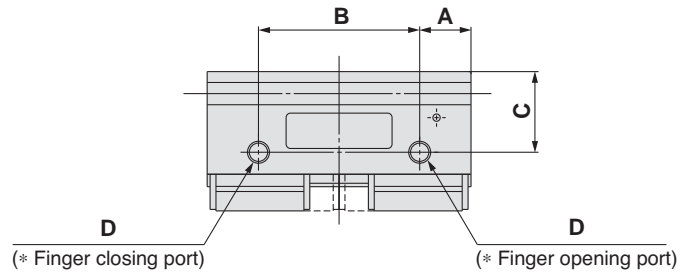

### Body Option Dimension (mm)

Model	A	B	C	D
MHF2-8DR	5.5	25	11	M3 x 0.5
MHF2-8D1R		37		

**MHF2-8D2R**  
**MHF2-12D□R**  
**MHF2-16D□R**  
**MHF2-20D□R**

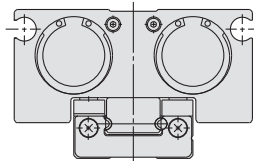

Port side of axial piping type

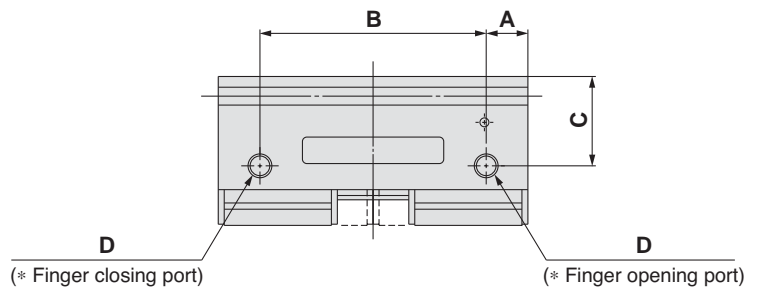

### Body Option Dimension (mm)

Model	A	B	C	D
MHF2-8D2R	5.5	61	11	M3 x 0.5
MHF2-12DR	7	38	14.8	M5 x 0.8
MHF2-12D1R		54		
MHF2-12D2R		90		
MHF2-16DR	9	54	19	M5 x 0.8
MHF2-16D1R		76		
MHF2-16D2R		124		
MHF2-20DR	10	66	23	M5 x 0.8
MHF2-20D1R		94		
MHF2-20D2R		154		

\* For dimensions not given above, please refer to the table of dimensions on pages 5-88 to 5-99.



## Auto Switch Hysteresis

Auto switches have hysteresis similar to micro switches. Use the table below as a guide when adjusting auto switch positions, etc.

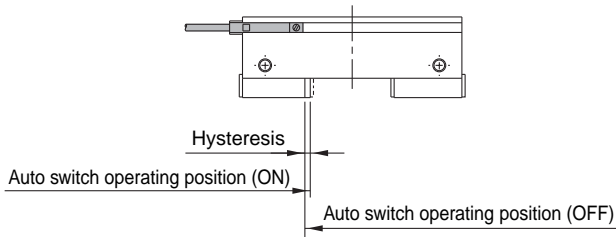

## Hysteresis

	D-M9□(V)	D-M9□W(V)	
		Red ON	Green ON
MHF2-8D□	0.5	0.5	1
MHF2-12D□	0.5	0.5	1
MHF2-16D□	0.5	0.5	1
MHF2-20D□	0.5	0.5	1

## Auto Switch Mounting

Insert the auto switch into the switch mounting groove in the air chuck in the direction shown below, and after setting the mounting position, tighten the attached switch mounting screw with a screwdriver.

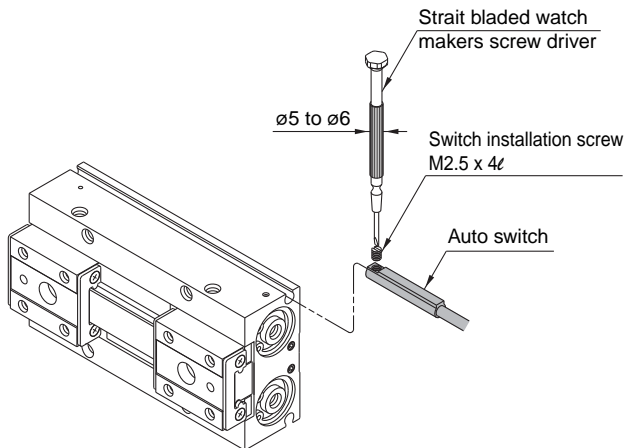

Note) Use a screwdriver with a grip diameter of 5 to 6 mm to tighten the auto switch mounting screw. The tightening torque should be about 0.05 to 0.1N·m. When you begin to feel that the screw is being tightened, turn it further by 90°.

## ⚠ Caution

When using an auto switch on the mounting plate side, the switch will protrude from the end face as shown below. Please provide a runoff space of 2mm or deeper on the mounting plate.

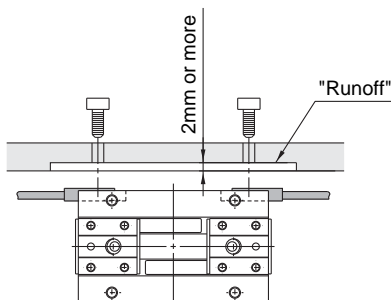

## Auto Switch Protrusion from the Body End Surface

- The amount of auto switch protrusion from the body end surface is shown in the table below.
- Use this as a standard when mounting, etc.

### Auto switch protrusion

Lead wire type	In-line entry		Perpendicular entry		
	D-M9□	D-M9□W	D-M9□V	D-M9□WV	
Illustration					
Auto switch					
Finger position					
Model	D-M9□	D-M9□W	D-M9□V	D-M9□WV	
MHF2-8D	Open	6.5	6.5	4.5	4.5
	Close	6.5	6.5	4.5	4.5
MHF2-8D1	Open	6.5	6.5	4.5	4.5
	Close	6.5	6.5	4.5	4.5
MHF2-8D2	Open	0.5	0.5	—	—
	Close	0.5	0.5	—	—
MHF2-12D	Open	3	3	1	1
	Close	3	3	1	1
MHF2-12D1	Open	1	1	—	—
	Close	1	1	—	—
MHF2-12D2	Open	—	—	—	—
	Close	—	—	—	—
MHF2-16D	Open	—	—	—	—
	Close	—	—	—	—
MHF2-16D1	Open	—	—	—	—
	Close	—	—	—	—
MHF2-16D2	Open	—	—	—	—
	Close	—	—	—	—
MHF2-20D	Open	—	—	—	—
	Close	—	—	—	—
MHF2-20D1	Open	—	—	—	—
	Close	—	—	—	—
MHF2-20D2	Open	—	—	—	—
	Close	—	—	—	—

Note) There is no protrusion for sections of the table with no values entered.

# Series MHF2

## Installation and Setting of Auto Switch

Various auto switch applications are possible through different combinations of auto switch quantity and detecting positions.

### 1) Detection of work (External holding)

Detection example		① Confirmation of finger reset position	② Confirmation of work holding	③ Confirmation of work releasing
Detecting position	Finger fully open position		Work holding position	Finger fully closed position
	Operation of auto switch	Switch ON at finger reset position (Light: ON)	Switch ON at work holding position (Light: ON)	At work holding position [Normal operation] : Switch OFF (Light: OFF) Work releasing condition [Abnormal operation] : Switch ON (Light: ON)
Combination of detection	One auto switch	●	●	●
	Two auto switches	●—●	●—●	●—●
Auto switch mounting position /setting procedure	Procedure 1) Fully open the fingers.		Procedure 1) Locate the fingers in the work holding position.	
	<input type="checkbox"/> Connect a switch applying no or low voltage and follow the procedures for setting.	Procedure 2) Insert the auto switch mounting groove from the direction shown in the figure.		
	Procedure 3) Slide auto switch in the direction of the arrow until the indicator light comes on.	Procedure 3) Slide auto switch in the direction of the arrow until the indicator lights. Move switch a further 0.3 to 0.5mm in the direction of the arrow and set.		
		Indicator lighting position		
	Procedure 4) Slide the auto switch a further distance in the direction of the arrow until the indicator light goes out.			
	Procedure 5) Move the auto switch in the opposite direction, as shown by the arrow, a distance of 0.3 to 0.5mm and set.	Fitting position		

Note) •It is recommended that work be held at the center of the finger stroke.

•If work is held around the end position of finger opening stroke, the above detecting combination may be limited due to the ON/OFF differential of the auto switches.

# Series MHF2

## Installation and Setting of Auto Switch

Various auto switch applications are possible through different combinations of auto switch quantity and detecting positions.

### 2) Detection of work (Internal holding)

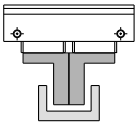
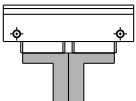
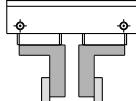
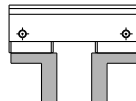
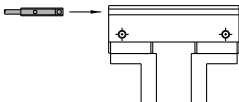
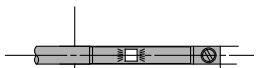
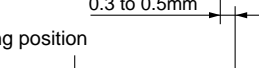
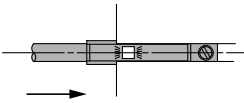
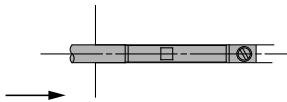
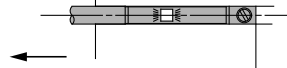
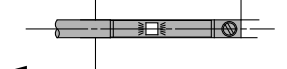
Detection example		① Confirmation of finger reset position	② Confirmation of work holding	③ Confirmation of work releasing
Detecting position	Finger fully closed position		Work holding position	Finger fully open position
Operation of auto switch	Switch ON at finger reset position (Light: ON)		Switch ON at work holding position (Light: ON)	At work holding position [Normal operation] : Switch OFF (Light: OFF) Work releasing condition [Abnormal operation] : Switch ON (Light: ON)
Combination of detection	One auto switch	●	●	●
	Two auto switches	●—●	●—●	●—●
		●—●—●	●—●—●	●—●—●
Auto switch mounting position /setting procedure		<b>Procedure 1)</b> Fully open the fingers. 	<b>Procedure 1)</b> Locate the fingers in the work holding position. 	<b>Procedure 1)</b> Locate the fingers in the fully closed position. 
<input type="checkbox"/> Connect a switch applying no or low voltage and follow the procedures for setting.		<b>Procedure 2)</b> Insert the auto switch mounting groove from the direction shown in the following drawing. 		
<b>Procedure 3)</b> Slide auto switch in the direction of the arrow until the indicator lights comes on. Move switch a further 0.3 to 0.5mm in the direction of the arrow and set. Indicator lighting position  Fitting position  0.3 to 0.5mm		<b>Procedure 3)</b> Slide auto switch in the direction of the arrow until the indicator lights.  <b>Procedure 4)</b> Slide the auto switch a further distance in the direction of the arrow until the indicator light goes out.  <b>Procedure 5)</b> Move the auto switch in the opposite direction, as shown by the arrow, a distance of 0.3 to 0.5mm and set. Indicator lighting position  Fitting position  0.3 to 0.5mm		

Note) •It is recommended that work be held at the center of the finger stroke.

•If work is held around the end position of finger opening stroke, the above detecting combination may be limited due to the ON/OFF differential of the auto switches.



### 1 With An Adjustable Opening/Closing Finger Positioning

Symbol

**-X83**

- Stroke can be adjusted to suit the workpiece
- 3 types of opening/closing finger stroke adjustments (Adjustable finger opening/closing position type, Adjustable finger opening position type, Adjustable finger closed position type)

### Various strokes

- Standardised 3 stroke types and 2 stroke adjustment types for fine tuning.

Bore size (mm)	Short stroke		Medium stroke		Long stroke	
	Full stroke	Stroke adjustable width	Full stroke	Stroke adjustable width	Full stroke	Stroke adjustable width
ø8	8 mm	Short Adjuster 4 mm Long Adjuster 8 mm	16 mm	Short Adjuster 6 mm Long Adjuster 10 mm	32 mm	Short Adjuster 12 mm Long Adjuster 22 mm
ø12	12 mm	Short Adjuster 8 mm Long Adjuster 12 mm	24 mm	Short Adjuster 8 mm Long Adjuster 14 mm	48 mm	Short Adjuster 18 mm Long Adjuster 28 mm
ø16	16 mm	Short Adjuster 10 mm Long Adjuster 14 mm	32 mm	Short Adjuster 8 mm Long Adjuster 18 mm	64 mm	Short Adjuster 16 mm Long Adjuster 36 mm
ø20	20 mm	Short Adjuster 8 mm Long Adjuster 18 mm	40 mm	Short Adjuster 10 mm Long Adjuster 20 mm	80 mm	Short Adjuster 20 mm Long Adjuster 40 mm

### How to Order

MHF2 - Standard part number - X83 A 2

• Stroke adjustable width

1	Short Adjuster
2	Long Adjuster

• Stroke adjustable side

A	Both sides
B	Opening side
C	Closed side

- With an adjustable opening/closing finger positioning

## Specifications

### Finger stroke adjustable width for opening/closing position

(mm)

Model	Full stroke	Adjustable stroke width	A: Adjustable finger opening/closing position type		B: Adjustable finger opening position type	C: Adjustable finger closing position type
			Adjustable stroke width		Adjustable stroke width for opening position	Adjustable stroke width for closed position
			Closed position	Opening position		
MHF2-8D□	8	4	0 to 4	4 to 8	4 to 8	0 to 4
			0 to 8	0 to 8	0 to 8	0 to 8
MHF2-8D1□	16	6	0 to 6	10 to 16	10 to 16	0 to 6
			0 to 10	6 to 16	6 to 16	0 to 10
MHF2-8D2□	32	12	0 to 12	20 to 32	20 to 32	0 to 12
			0 to 22	10 to 32	10 to 32	0 to 22
MHF2-12D□	12	8	0 to 8	4 to 12	4 to 12	0 to 8
			0 to 12	0 to 12	0 to 12	0 to 12
MHF2-12D1□	24	8	0 to 8	16 to 24	16 to 24	0 to 8
			0 to 14	10 to 24	10 to 24	0 to 14
MHF2-12D2□	48	18	0 to 18	30 to 48	30 to 48	0 to 18
			0 to 28	20 to 48	20 to 48	0 to 28
MHF2-16D□	16	10	0 to 10	6 to 16	6 to 16	0 to 10
			0 to 14	2 to 16	2 to 16	0 to 14
MHF2-16D1□	32	8	0 to 8	24 to 32	24 to 32	0 to 8
			0 to 18	14 to 32	14 to 32	0 to 18
MHF2-16D2□	64	16	0 to 16	48 to 64	48 to 64	0 to 16
			0 to 36	28 to 64	28 to 64	0 to 36
MHF2-20D□	20	8	0 to 8	12 to 20	12 to 20	0 to 8
			0 to 18	2 to 20	2 to 20	0 to 18
MHF2-20D1□	40	10	0 to 10	30 to 40	30 to 40	0 to 10
			0 to 20	20 to 40	20 to 40	0 to 20
MHF2-20D2□	80	20	0 to 20	60 to 80	60 to 80	0 to 20
			0 to 40	40 to 80	40 to 80	0 to 40

Note) Specifications and details other than above are the same as standard type.

### How to Adjust Finger Stroke

After adjusting the opening/closing width adjustment thread, tighten the nut to fix.

#### Nut tightening torque

Part no.	Thread size	Tightening torque N·m
MHF2-8D□-X83□□	M4 x 0.7	1.5
MHF2-8D□R-X83□□		
MHF2-12D□-X83□□	M5 x 0.8	3.0
MHF2-12D□R-X83□□		
MHF2-16D□-X83□□	M6 x 1.0	5.2
MHF2-16D□R-X83□□		
MHF2-20D□-X83□□	M8 x 1.25	12.5
MHF2-20D□R-X83□□		

## Warning

### 1. Adjust the stroke adjustment screw within the adjustable width.

If you adjust the adjustment screw beyond the maximum value, the adjustment screw may fall out and may cause damage to human bodies or equipment/devices.

### 2. Do not adjust stroke when air pressure is applied to the adjustment screw side.

If air pressure is applied to the adjustment screw, the adjustment screw may fall out in some adjustment statuses. When applying pressure, make sure the adjustment screw is tightened enough.

# Series MHF2

## Dimensions (The dimensions below are the same as the standard type.)

### Adjustable finger opening/closing position type/MHF2-□-X83A1 X83A2

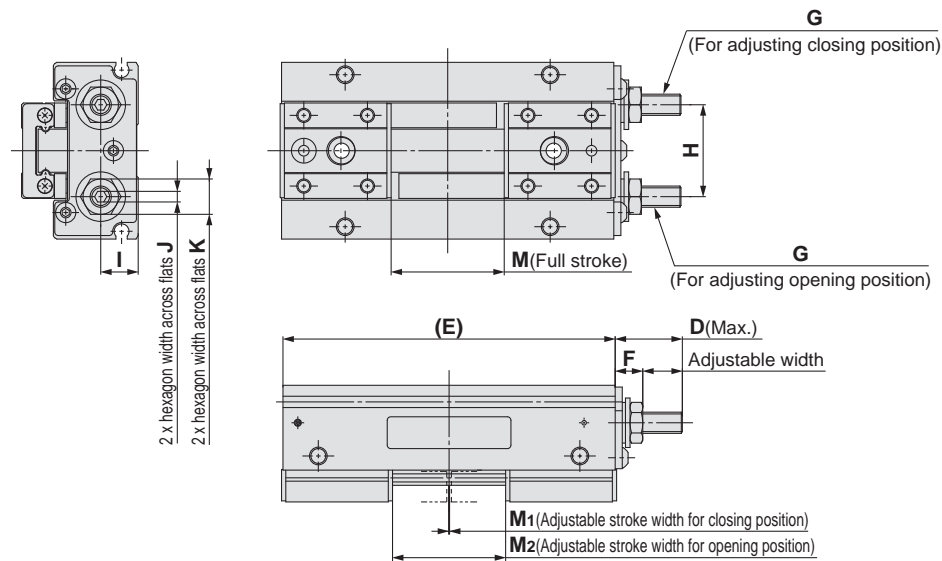

### Adjustable finger opening position type/MHF2-□-X83B1 X83B2

### Adjustable finger closing position type/MHF2-□-X83C1 X83C2

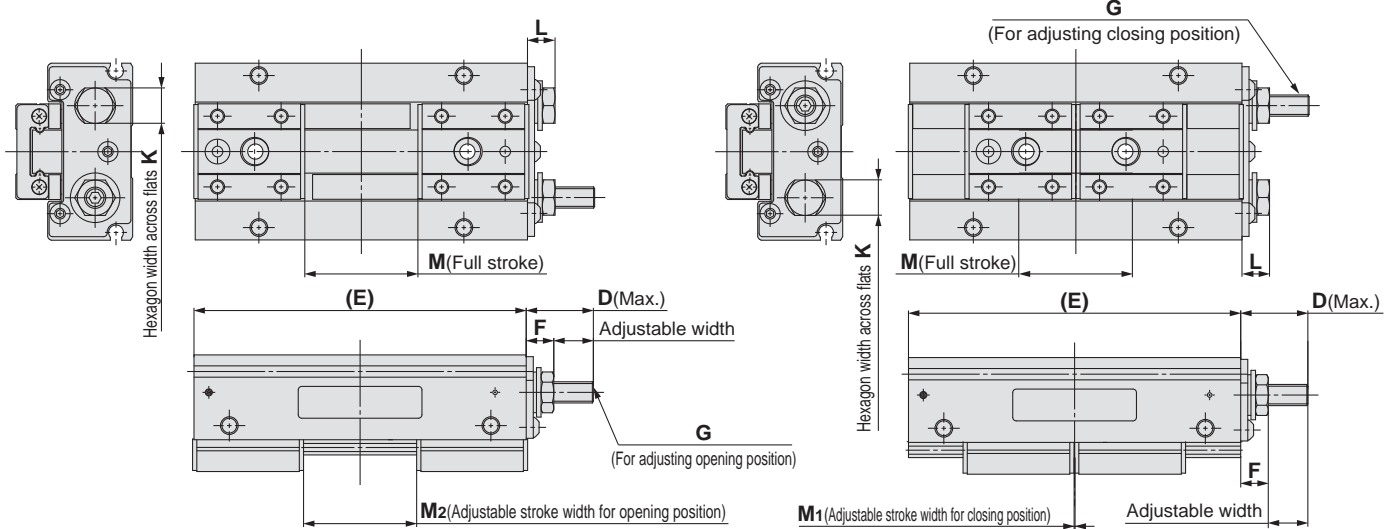

## Dimensions (□ in the table below indicates the symbol for stroke adjustable side (A: Adjustable finger opening/closing position type, B: Adjustable finger opening position type, or C: Adjustable finger closing position type).) (mm)

Model	A: Adjustable finger opening/closing position type B: Adjustable finger opening position type C: Adjustable finger closing position type						D	(E)	F	G	H	I	J	K	L	M
	M1	M2	M1	M2	M1	M2										
MHF2-8D□	-X83□1	0 to 4	4 to 8	—	4 to 8	0 to 4	9	36	—	—	—	—	—	—	—	8
	-X83□2	0 to 8	0 to 8	—	0 to 8	0 to 8	12									
MHF2-8D1□	-X83□1	0 to 6	10 to 16	—	10 to 16	0 to 6	10	48	5	M4 x 0.7	15.8	5.9	2	7	4.6	16
	-X83□2	0 to 10	6 to 16	—	6 to 16	0 to 10	12									
MHF2-8D2□	-X83□1	0 to 12	20 to 32	—	20 to 32	0 to 12	13	72	—	—	—	—	—	—	—	32
	-X83□2	0 to 22	10 to 32	—	10 to 32	0 to 22	18									
MHF2-12D□	-X83□1	0 to 8	4 to 12	—	4 to 12	0 to 8	12	52	—	—	—	—	—	—	—	12
	-X83□2	0 to 12	0 to 12	—	0 to 12	0 to 12	14									
MHF2-12D1□	-X83□1	0 to 8	16 to 24	—	16 to 24	0 to 8	12	68	5.9	M5 x 0.8	20	7.7	2.5	8	5.4	24
	-X83□2	0 to 14	10 to 24	—	10 to 24	0 to 14	15									
MHF2-12D2□	-X83□1	0 to 18	30 to 48	—	30 to 48	0 to 18	18	104	—	—	—	—	—	—	—	48
	-X83□2	0 to 28	20 to 48	—	20 to 48	0 to 28	23									
MHF2-16D□	-X83□1	0 to 10	6 to 16	—	6 to 16	0 to 10	15	72	—	—	—	—	—	—	—	16
	-X83□2	0 to 14	2 to 16	—	2 to 16	0 to 14	17									
MHF2-16D1□	-X83□1	0 to 8	24 to 32	—	24 to 32	0 to 8	14	94	7.8	M6 x 1	26	10.6	3	10	7.4	32
	-X83□2	0 to 18	14 to 32	—	14 to 32	0 to 18	19									
MHF2-16D2□	-X83□1	0 to 16	48 to 64	—	48 to 64	0 to 16	18	142	—	—	—	—	—	—	—	64
	-X83□2	0 to 36	28 to 64	—	28 to 64	0 to 36	28									
MHF2-20D□	-X83□1	0 to 8	12 to 20	—	12 to 20	0 to 8	18	86	—	—	—	—	—	—	—	20
	-X83□2	0 to 18	2 to 20	—	2 to 20	0 to 18	23									
MHF2-20D1□	-X83□1	0 to 10	30 to 40	—	30 to 40	0 to 10	18	114	10.2	M8 x 1.25	33	13	4	13	9.9	40
	-X83□2	0 to 20	20 to 40	—	20 to 40	0 to 20	23									
MHF2-20D2□	-X83□1	0 to 20	60 to 80	—	60 to 80	0 to 20	23	174	—	—	—	—	—	—	—	80
	-X83□2	0 to 40	40 to 80	—	40 to 80	0 to 40	33									



# Series MHF2 Specific Product Precautions 1

Be sure to read this before handling the products.

## Mounting

### Warning

1. Do not scratch or dent the air gripper by dropping or bumping it when mounting.

Slight deformation can cause inaccuracy or a malfunction.

2. Tighten the screw within the specified torque range when mounting the attachment.

Tightening with a torque above the limit can cause malfunction, while insufficient tightening can cause slippage and dropping.

### How to Mount Attachment to the Finger

Make sure to mount the attachments on fingers with the tightening torque in the table below by using bolts, etc., for the female threads on fingers.

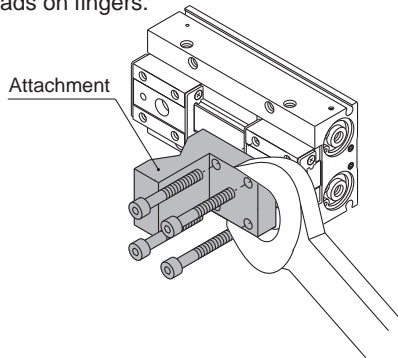

Model	Bolt	Max. tightening torque N-m
MHF2-8D□	M2.5 x 0.45	0.36
MHF2-12D□	M3 x 0.5	0.63
MHF2-16D□	M4 x 0.7	1.5
MHF2-20D□	M4 x 0.7	1.5

3. Tighten the screw within the specified torque range when mounting the air gripper.

Tightening with a torque above the limit can cause malfunction, while insufficient tightening can cause slippage and dropping.

### How to Mount Air Grippers

#### Top mounting (Body tapped)

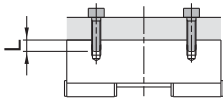

Model	Bolt	Max. tightening torque N-m	Max. screw-in depth L mm
MHF2-8D	M3 x 0.5	0.95	7
MHF2-12D	M4 x 0.7	2.2	10
MHF2-16D	M5 x 0.8	4.5	12
MHF2-20D	M6 x 1	7.8	15

#### Lateral mounting (Body tapped)

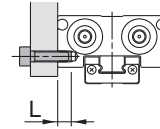

Model	Bolt	Max. tightening torque N-m	Max. screw-in depth L mm
MHF2-8D	M3 x 0.5	0.63	4
MHF2-12D	M4 x 0.7	1.5	5
MHF2-16D	M5 x 0.8	3	5.5
MHF2-20D	M6 x 1	5.2	6

#### Bottom mounting (Body tapped, body through-hole)

##### ● Body tapped

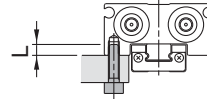

Model	Bolt	Max. tightening torque N-m	Max. screw-in depth L mm
MHF2-8D	M3 x 0.5	0.63	4
MHF2-12D	M4 x 0.7	1.5	5
MHF2-16D	M5 x 0.8	3	5.5
MHF2-20D	M6 x 1	5.2	6

##### ● Body through-hole

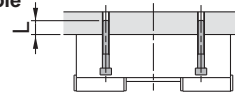

Model	Bolt	Max. tightening torque N-m	Screw-in depth L mm
MHF2-8D	M2.5 x 0.45*	0.36	4
MHF2-12D	M3 x 0.5*	0.63	5.2
MHF2-16D	M4 x 0.7	1.5	—
MHF2-20D	M5 x 0.8	3	—

\* When MHF2-8D□ and MHF2-12D□ are mounted body through-hole, use the attached special bolts.

## Operating Environment

### Caution

Use caution for the anti-corrosiveness of the linear guide section.

Martensitic stainless steel is used for the finger guide rail, so make sure that anti-corrosiveness is inferior to the austenitic stainless steel. In particular, watch for rust in environments where waterdrops are likely to adhere due to condensation.



# Series MHF2 Specific Product Precautions 2

Be sure to read this before handling the products.

## Operating Precautions

### ⚠ Caution

#### How to Locate Finger and Attachment

##### ● Positioning in the finger's open/close direction

Position the finger and the attachment by inserting the finger's pin into the attachment's pin insertion hole.

Provide the following pin insertion hole dimensions: shaft-basis fitting dimension **C** for the open/close direction; slotted hole with relief **B** for the cross direction.

##### ● Positioning in the finger's cross direction

Perform the positioning from the reference plane of the finger and the side A of the attachment.

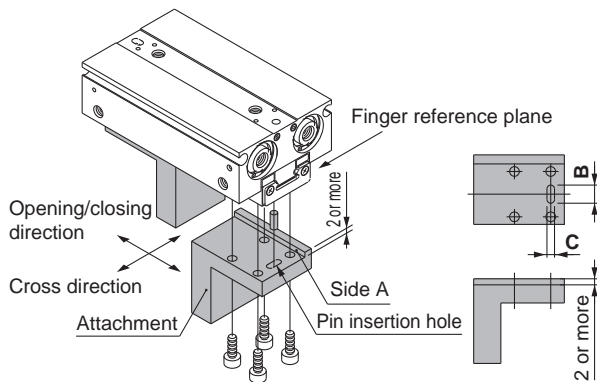

Finite orbit type guide is used in the actuator finger part. By using this, when there are inertial force which cause by movements or rotation to the actuator, steel ball will move to one side and this will cause a large resistance and degrade the accuracy. When there are inertial force which cause by movements or rotation to the actuator, operate the finger to full stroke.

Especially in long stroke type, the accuracy of finger may degrade.